



Manual on

# Electronic Voting Machine and VVPAT

January 2017  
Document 2 - Edition 2



भारत निर्वाचन आयोग  
**Election Commission of India**

Nirvachan Sadan, Ashoka Road, New Delhi-110001

*“No voter to be left behind”*



# Manual on Electronic Voting Machine and VVPAT

January 2017



भारत निर्वाचन आयोग  
**Election Commission of India**

Nirvachan Sadan, Ashoka Road, New Delhi-110001

*“No voter to be left behind”*



## FOREWORD

The use of Electronic Voting Machines has revolutionised the Electoral System and introduction of Voter Verifiable Paper Audit Trail system has provided greater transparency to the poll process.

This Manual on Electronic Voting Machine and VVPAT has been prepared with the view to familiarise the readers with the genesis of the Electronic Voting Machine, Process of its Development, Procurement, Storage and legal provisions. On the other side this Manual contains all important instructions on Use of Electronic Voting Machines and Voter Verifiable Paper Audit Trail, making it useful handbook on the subject for the Electoral machinery handling the Electronic Voting Machines and Voter Verifiable Paper Audit Trail system from time to time.

It is hoped that this Manual will prove useful to all election related officials and other stakeholders. The Commission would welcome suggestions from all users of this Manual for making it more informative and useful.

January, 2017

**Election Materials Division**  
**Election Commission of India**  
**New Delhi**



## Amendments & Corrigenda

Amendments				Corrigenda			
S. No.	Date	Subject	Page No.	S. No.	Date	Subject	Page No.
1	15.07.16	Storage of EVMs and Opening of EVM Warehouse, During Non-Election Period	4, 26,	1.		Para 5.8.1 & 5.8.2 deleted and subsequent paras renumbered.	39
2	28.03.16	Storage of EVMs and Opening of EVM Warehouse, During Election Period, Post Poll Storage.	30, 34-35 41-42 59	2		Para 5.8.1 to 5.8.5 added in the end of chapter 6 under the sub-head “6.4 Security Measures” as paras 6.4.1 to 6.4.5.	41-42
3	05.05.16	Instructions relating to Counting of Votes	63 -65	3		A new para 17.4.5 added and existing para 17.4.6 deleted.	63-64
4	14.06.16	EVM Tracking Software-Mobile Application	72-74				
5	04.01.16	Voter Verifiable Paper Audit Trail (VVPAT) Brochure	99-106				
6	29.03.16	Voter Verifiable Paper Audit Trail (VVPAT) Poster	107				
7	29.03.16	EVM Poster	108				

S. No.	Date	Subject	Page No.	S. No.	Date	Subject	Page No.
8	17.03.16	Voter Verifiable Paper Audit Trail (VVPAT), Conduct of Mock Poll and Sealing of EVMs and VVPATs in the Polling Station.	91, 115				
9	27.05.16	Repairing of Defective EVMs (New Chapter)	117-118				
10		Various Types of Seals used for sealing of EVMs & VVPATs (New Chapter)	109-116				
11	17.10.2016	Disposal of EVMs – New guidelines incorporated.	67-68				
12	15.11.2016	Voting Compartment to be used in Polling Stations (New Chapter) and subsequent chapters renumbered	52				
13	17.11.2016	Para 15.2 containing instructions on EVM in case of Re-poll has been amended.	58				



## Table of contents

<b>FOREWORD</b>		<b>I</b>
<b>AMENDMENTS</b>		<b>III</b>
		<b>Page</b>
<b>CHAPTER 1.</b>	<b>Introduction</b>	<b>1</b>
<b>CHAPTER 2.</b>	<b>Flow Chart (EVM process at a Glance)</b>	<b>3</b>
<b>CHAPTER 3.</b>	<b>Legal provision for the use of EVMs &amp; VVPATs</b>	<b>6</b>
<b>3.1</b>	<b>The Representation of the People Act, 1951</b>	<b>6</b>
<b>3.2</b>	<b>Conduct of Election Rules, 1961 (Statutory Rules and Orders)</b>	<b>11</b>
<b>CHAPTER 4.</b>	<b>Storage of EVMs and Opening of EVM-Warehouse</b>	<b>26</b>
<b>4.1</b>	<b>During Non-Election period</b>	<b>26</b>
4.1.1	Physical Verification of EVMs	26
4.1.2	Storage of EVMs	27
4.1.3	Movement of EVMs	28
<b>4.2</b>	<b>During Election period</b>	<b>28</b>
4.2.1	Physical Verification of EVMs	28
4.2.2	Storage of EVMs	29
4.2.2.1	Pre-Poll storage	29
4.2.2.2	Post-Poll storage	29
Note-1 :	Procedure for storing polled EVMs	32
Note-2:	Retention period for polled EVMs	34
<b>CHAPTER 5.</b>	<b>First Level Checking of EVMs (FLC)</b>	<b>36</b>
<b>5.1</b>	<b>FLC when to be done</b>	<b>36</b>
<b>5.2</b>	<b>FLC to be done in the presence of representatives of Political Parties</b>	<b>36</b>
<b>5.3</b>	<b>Arrangements in the premises of FLC</b>	<b>36</b>
<b>5.4</b>	<b>Manpower in FLC</b>	<b>37</b>

5.5	Work to be done during FLC	37
5.6	Sealing of plastic cabinet of Control Unit of EVMs with pink paper seal	38
5.7	Supervision of FLC	39
5.8	Security measures for EVMs after FLC of EVMs	39
<b>CHAPTER 6.</b>	<b>First Randomization of EVMs</b>	<b>40</b>
6.1	Process of first Randomization	40
6.2	Communication of the list of Randomized CUs and Bus to Political Parties	40
6.3	Taking charge of EVMs by RO	41
6.4	Security Measures	41
<b>CHAPTER 7.</b>	<b>Second Randomization of EVMs</b>	<b>43</b>
7.1	Second Randomization	43
7.2	Allocation of additional BUs	43
7.3	Cascading of BUs	44
<b>CHAPTER 8.</b>	<b>Preparation of EVMs (Candidate Set)</b>	<b>45</b>
8.1	When preparation of EVMs to be done	45
8.2	Arrangement in the premises of preparation of EVM	45
8.3	Manpower for preparation	46
8.4	Additional tasks during preparation	46
8.4.1	Checking of Balloting Units (BUs)	46
8.4.2	Conduct of Mock Poll	47
8.4.3	Demonstration of printout of results	47
8.4.4	Sealing of plastic cabinet of BU with pink paper seal	47
8.4.5	Supervision of the preparation	48
<b>CHAPTER 9.</b>	<b>Instructions on dispersal of EVMs</b>	<b>49</b>
<b>CHAPTER 10.</b>	<b>Instructions to Zonal / Sector / Area Officers regarding EVMs</b>	<b>50</b>

<b>CHAPTER 11.</b>	Voting Compartment to be used in Polling Stations	52
<b>CHAPTER 12.</b>	Instructions on Use of EVMs in Polling Stations	53
<b>CHAPTER 13.</b>	Mock poll on the day of Poll	54
13.1	Mock poll before commencement of actual poll	54
13.2	Mock poll in case of replacement of EVM	55
13.3	Recording of Poll Start and Poll End Date and Time	56
<b>CHAPTER 14.</b>	Replacement of EVMs during Poll	57
<b>CHAPTER 15.</b>	Instructions on EVM in case of Re-poll	58
<b>CHAPTER 16.</b>	Security measures for polled EVM stored for counting of votes	59
<b>CHAPTER 17.</b>	Instructions relating to Counting	61
17.1	General Instructions	61
17.2	Procedure in case of discrepancy in the date and time of start and end of poll	61
17.3	Procedure in case the close button not pressed at the end of poll	62
17.4	Instructions in case of EVMs malfunctioning at the time of Counting	63
17.5	Sealing of EVMs after counting of votes	66
<b>CHAPTER 18.</b>	Disposal of EVMs	67
<b>CHAPTER 19.</b>	Technical Expert Committee on EVMs and VVPATs	69
<b>CHAPTER 20.</b>	EVM Tracking Software	71
20.1	Mobile Applications	72
<b>CHAPTER 21.</b>	EVM Brochure for Candidates	75

<b>CHAPTER 22.</b>	<b>Voter Verifiable Paper Audit Trail (VVPAT)</b>	<b>81</b>
22.1	Introduction	81
22.2	Facts on VVPAT	82
22.3	Legal Provision [The Conduct of Elections (Amendment) Rules, 2013]	82
22.4	Training of Master Trainers on VVPAT	87
22.5	Awareness about use of VVPAT	88
22.6	First Level Checking of VVPAT System	88
22.7	Preparation of EVMs and VVPAT system for Poll	89
22.8	Additional Polling Official	90
22.9	Dispersal of Polling parties	91
22.10	Conduct of Mock Poll and sealing of EVM and VVPAT in the Polling Station	91
22.11	Complaint about incorrect printing of particulars on paper slip	92
22.12	Action in case of certain contingencies during poll	94
22.13	Counting of paper slips of VVPAT	95
22.14	Sealing of VVPAT units after counting of votes	97
22.15	VVPAT Brochure for Presiding Officers	99
22.16	How to Vote Using EVM & VVPATs	107
22.17	How to Vote Using EVM	108
<b>CHAPTER 23.</b>	<b>Various Types of Seals Used for Sealing EVMs &amp; VVPATs</b>	<b>109</b>
<b>CHAPTER 24.</b>	<b>Repairing of Defective EVMs &amp; VVPATs</b>	<b>117</b>
<b>ANNEXURES</b>		<b>119- 150</b>
<b>SELECTED REFERENCES</b>		<b>151</b>
<b>IMPORTANT JUDGEMENTS</b>		<b>152</b>
<b>FREQUENTLY ASKED QUESTIONS ON EVMs</b>		<b>155</b>
<b>FREQUENTLY ASKED QUESTIONS ON VVPATs</b>		<b>166</b>

# CHAPTER – 1

## INTRODUCTION

The Electronic Voting Machine (EVM), the replacement of the ballot box is mainstay in the electoral process. First conceived in 1977 in the Election Commission, the Electronics Corporation of India Ltd. (ECIL), Hyderabad was assigned the task to design and develop it. In 1979 a proto-type was developed, which was demonstrated by the Election Commission before the representatives of political parties on 6th August, 1980. The Bharat Electronic Ltd. (BEL), Bangalore, another public sector undertaking, was co-opted along with ECIL to manufacture EVMs once a broad consensus was reached on its introduction.

First time use of EVMs occurred in the general election in Kerala in May, 1982; however, the absence of a specific law prescribing its use led to the Supreme Court striking down that election. Subsequently, in 1989, the Parliament amended the Representation of the People Act, 1951 to create a provision for the use of EVMs in the elections (chapter 3). A general consensus on its introduction could be reached only in 1998 and these were used in 25 legislative assembly constituencies spread across three states of Madhya Pradesh, Rajasthan and Delhi. Its use was further expanded in 1999 to 45 parliamentary constituencies and later, in February 2000, to 45 assembly constituencies of the Haryana assembly elections. In the state assembly elections, held in May 2001, in the states of Tamil Nadu, Kerala, Pondicherry and West Bengal, the EVMs were used in all the assembly constituencies. Since then, for every state assembly elections, the Commission has used the EVMs. In 2004, in the general election to the Lok Sabha, the EVMs (more than one million) were used in all 543 parliamentary constituencies in the country.

An EVM consists of two units, namely, Control Unit (CU) and Balloting Unit (BU) with a cable (5 mtr long) for connecting the both. A Balloting Unit caters upto 16 candidates. There are number of variants available for the EVMs. Time-to-time, it has evolved and has become more robust. In case of pre-2006 and post-2006 EVMs, 4 (Four) Balloting Units can be cascaded together to accommodate upto a maximum of 64 candidates (including NOTA), which can be used with one Control Unit. In case of upgraded post-2006 EVMs, 24 (Twenty Four) Balloting Units can be cascaded together catering to 384 candidates (including NOTA) which can be used with one Control Unit. It runs on a power pack (Battery) having 7.5 volts. In case of upgraded post-2006 EVM, power packs are inserted in 5th, 9th, 13th, 17th & 21st Balloting Units, if more than 4 BUs are connected to a Control Unit. On the right side of the BU along

the candidates' vote button, digits 1 to 16 are embossed in Braille signage for guidance of visually impaired electors. Subsequently, the Commission has introduced Voter Verifiable Paper Audit Trail (VVPAT) with the EVMs in select assembly constituencies to take the voting experience at higher level (Chapter 22).



**Control Unit**

**Balloting Unit**

The design and application of EVMs in the elections are considered a significant achievement in global democracy. It has brought more transparency, swiftness, and acceptability in the system. It has also helped in creating a vast pool of election officials well versed in its use. In its evolution, the Commission has issued series of instructions, frequently asked questions, and technical guidelines. During this period a number of judicial pronouncements has also helped in making the EVMs an integral component of our electoral system.

This Manual on EVMs is an important milestone in documentation as it brings all previous instructions and guidelines on a single platform for better readability. Divided in 24 chapters, it details legal framework, series of checking, randomization, storage instructions, setting of EVMs (with VVPAT), mock poll instructions, counting instructions, frequently asked questions, judicial decisions, and earlier references.

\*\*\*\*\*

## CHAPTER – 2

### FLOW CHART (EVM PROCESS AT A GLANCE) CONCEPT AND DESIGNING OF ELECTRONIC VOTING MACHINES (EVMS)

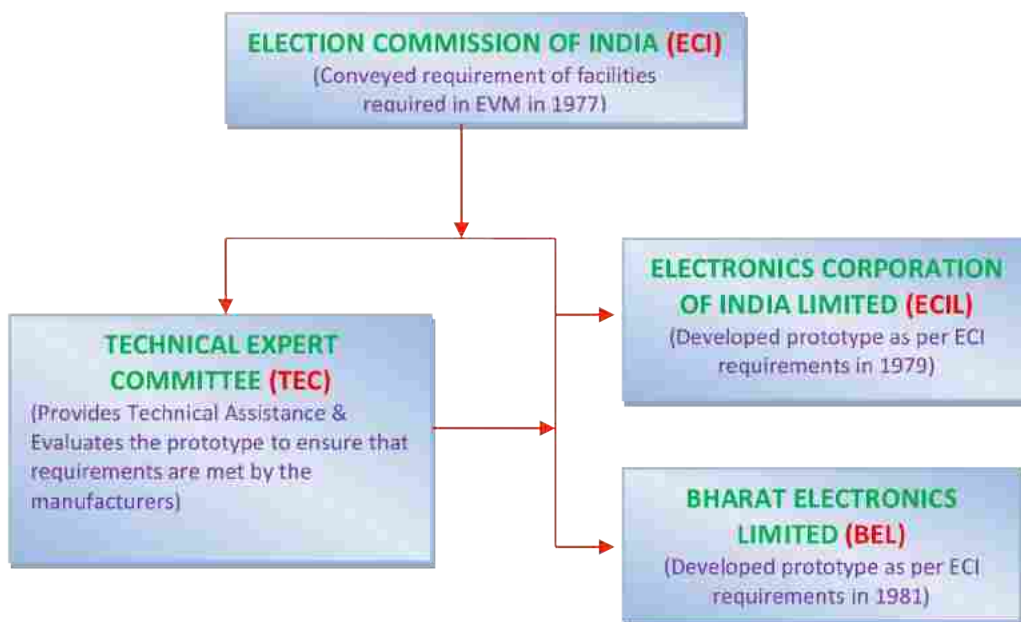

### PROCUREMENT OF EVMS

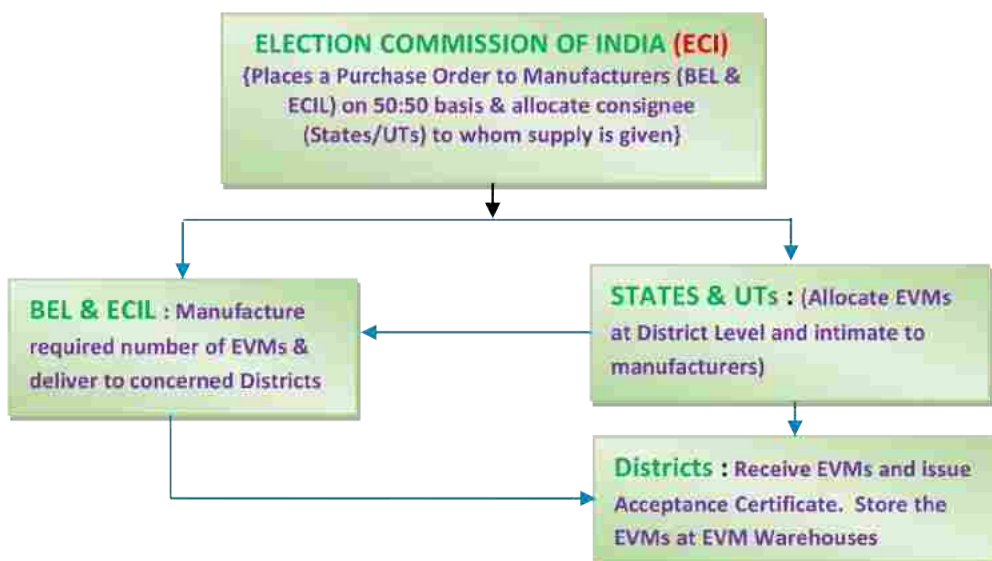

## USE OF EVMS IN ELECTIONS

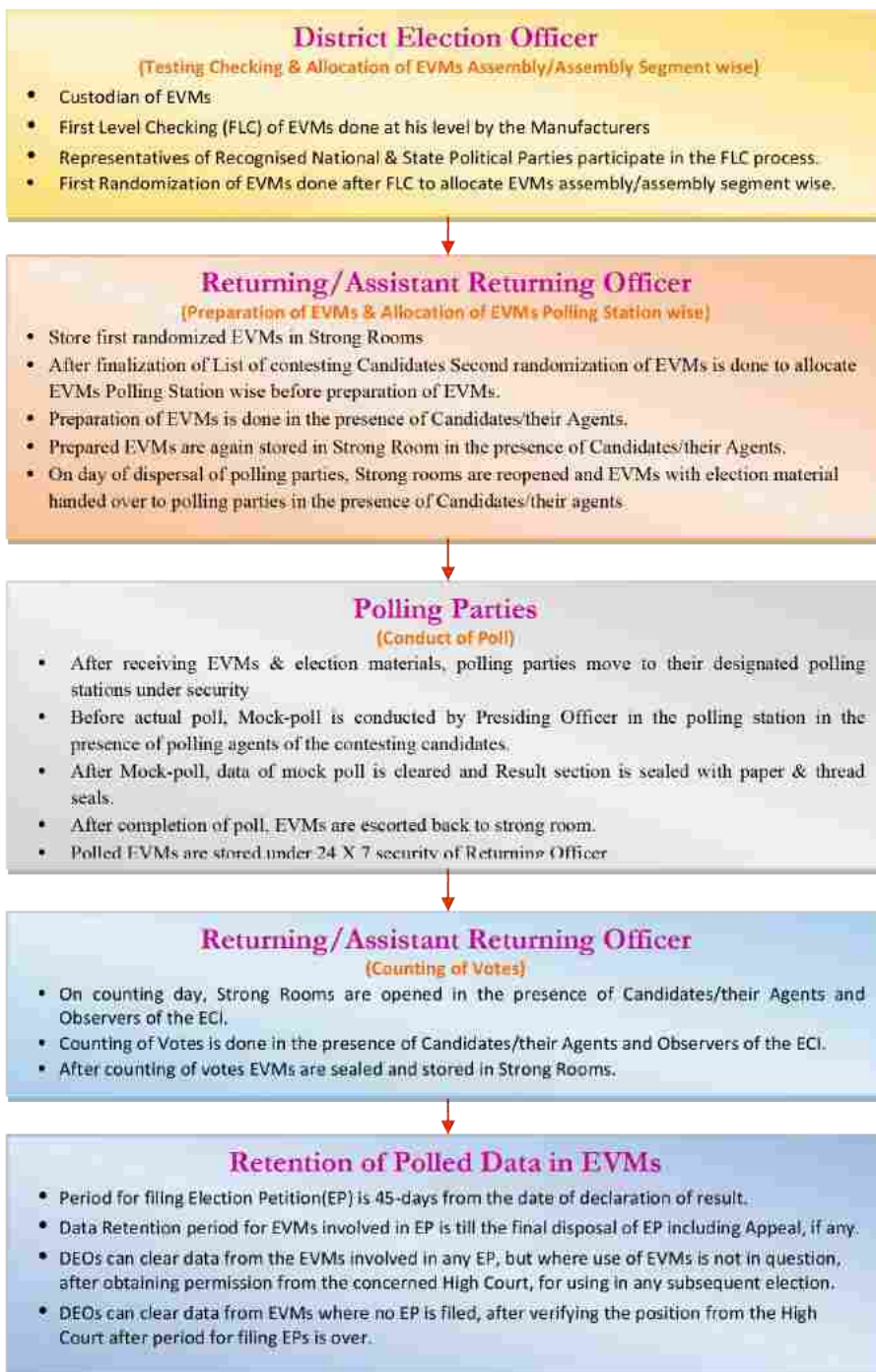



**STANDARD SCHEDULE FOR UPCOMING/POLL GOING STATES**

<b>PROCESS</b>	<b>TIME SCHEDULE</b>
1	2
Allocation of EVMs/VVPATs by ECI	Poll Gone C+30
Ordering of consumables LOI	Poll Gone C+30
Dispatch from Donor States	Poll Gone C+60
Receipt at Borrower States	P-120
FLC start	P-90
FLC completion	P-51
1st Randomization of EVMs	P-21
2nd Randomization of EVMs	P-14
Handing over of Defective EVMs to manufacturers at State HQs for repair	C+60
Completion of Repairs	C+90

**P = Poll day**

**C = Counting day**

## CHAPTER – 3

### LEGAL PROVISION FOR THE USE OF EVMs & VVPATs

**3.1** The Electronic Voting Machines were used for the first time during the General Election to the Kerala Legislative Assembly held from Parur Assembly Constituency in May, 1982 at 50 polling stations. Thereafter, these machines were used in ten other constituencies in 1982-83.

After 1983, the EVMs could not be used, as in the Election Appeal arising out of the election petition relating to the use of the machines in the election from Parur Assembly Constituency in Kerala, the Supreme Court ruled that there should be specific provision in the law providing for use of EVMs in elections.

Thereupon, the Election Commission of India recommended to the Government of India to amend the law suitably to provide legal sanction for the use of EVMs.

In December, 1988 a new section 61A was inserted in the Representation of the People Act, 1951, empowering the Election Commission of India to use Electronic Voting Machines in elections, which reads as under -

*“61A. Voting machines at elections.—Notwithstanding anything contained in this Act or the rules made thereunder, the giving and recording of votes by voting machines in such manner as may be prescribed, may be adopted in such constituency or constituencies as the Election Commission may, having regard to the circumstances of each case, specify.”*

*Explanation.—For the purpose of this section, “voting machine” means any machine or apparatus whether operated electronically or otherwise used for giving or recording of votes and any reference to a ballot box or ballot paper in this Act or the rules made thereunder shall, save as otherwise provided, be construed as including a reference to such voting machine wherever such voting machine is used at any election.*

The Supreme Court upheld the validity of the above provision in All India Anna Dravida Munnetra Kazhagam v/s. Chief Election Commissioner and others [2002(UJ)(1)387]

---

## THE REPRESENTATION OF THE PEOPLE ACT, 1951

58. Fresh poll in the case of destruction, etc., of ballot boxes.—

- (1) If at any election,—
  - (a) any ballot box used at a polling station or at a place fixed for the poll is unlawfully taken out of the custody of the presiding officer or the returning officer, or is accidentally or intentionally destroyed or lost, or is damaged or tampered with, to such an extent, that the result of the poll at that polling station or place cannot be ascertained; or
  - [(aa) any voting machine develops a mechanical failure during the course of the recording of votes; or]
  - (b) any such error or irregularity in procedure as is likely to vitiate the poll is committed at a polling station or at a place fixed for the poll, the returning officer shall forthwith report the matter to the Election Commission.
- (2) Thereupon the Election Commission shall, after taking all material circumstances into account; either—
  - (a) declare the poll at that polling station or place to be void, appoint a day, and fix the hours, for taking a fresh poll at that polling station or place and notify the day so appointed and the hours so fixed in such manner as it may deem fit, or
  - (b) if satisfied that the result of a fresh poll at that polling station or place will not, in any way, affect the result of the election or that 5[the mechanical failure of the voting machine or] the error or irregularity in procedure is not material, issue such directions to the returning officer as it may deem proper for the further conduct and completion of the election.
- (3) The provisions of this Act and of any rules or orders made thereunder shall apply to every such fresh poll as they apply to the original poll.]

### 61A. Voting machines at elections.—

Notwithstanding anything contained in this Act or the rules made thereunder, the giving and

recording of votes by voting machines in such manner as may be prescribed, may be adopted in such constituency or constituencies as the Election Commission may, having regard to the circumstances of each case, specify.

Explanation.—For the purpose of this section, “voting machine” means any machine or apparatus whether operated electronically or otherwise used for giving or recording of votes and any reference to a ballot box or ballot paper in this Act or the rules made thereunder shall, save as otherwise provided, be construed as including a reference to such voting machine wherever such voting machine is used at any election.]

**135A. Offence of booth capturing.—**

[(1)] Whoever commits an offence of booth capturing shall be punishable with imprisonment for a term which 6[shall not be less than one year but which may extend to three years and with fine, and where such offence is committed by a person in the service of the Government, he shall be punishable with imprisonment for a term which shall not be less than three years but which may extend to five years and with fine].

Explanation.— For the purposes of 7[this sub-section and section 20B], “booth capturing” includes, among other things, all or any of the following activities, namely:—

- (a) seizure of a polling station or a place fixed for the poll by any person or persons, making polling authorities surrender the ballot papers or voting machines and doing of any other act which affects the orderly conduct of elections;
- (b) taking possession of a polling station or a place fixed for the poll by any person or persons and allowing only his or their own supporters to exercise their right to vote and 6[prevent others from free exercise of their right to vote];
- (c) 8[coercing or intimidating or threatening directly or indirectly] any elector and preventing him from going to the polling station or a place fixed for the poll to cast his vote;

- (d) seizure of a place for counting of votes by any person or persons, making the counting authorities surrender the ballot papers or voting machines and the doing of anything which affects the orderly counting of votes;
  - (e) doing by any person in the service of Government, of all or any of the aforesaid activities or aiding or conniving at, any such activity in the furtherance of the prospects of the election of a candidate.]
- (2) An offence punishable under sub-section (1) shall be cognizable.]

**169. Power to make rules.—**

- (1) The Central Government may, after consulting the Election Commission, by notification in the Official Gazette, make rules<sup>1</sup> for carrying out the purposes of this Act.
- (2) In particular, and without prejudice to the generality of the foregoing power, such rules may provide for all or any of the following matters, namely:—
  - [(a) the form of affidavit under sub-section (2) of section 33A;]
  - [(aa)] the duties of presiding officers and polling officers at polling stations;
  - [(aaa) the form of contribution report;]
  - (b) the checking of voters by reference to the electoral roll;
  - [(bb) the manner of allocation of equitable sharing of time on the cable television network and other electronic media;]
  - (c) the manner in which votes are to be given both generally and in the case of illiterate voters or voters under physical or other disability ;
  - (d) the manner in which votes are to be given by a presiding officer, polling officer, polling agent or any other person, who being an elector for a constituency is authorised or appointed for duty at a polling station at which he is not entitled to vote;

- (e) the procedure to be followed in respect of the tender of vote by a person representing himself to be an elector after another person has voted as such elector;
  - [(ee) the manner of giving and recording of votes by means of voting machines and the procedure as to voting to be followed at polling stations where such machines are used;]
  - (f) the procedure as to voting to be followed at elections held in accordance with the system of proportional representation by means of the single transferable vote;
  - (g) the scrutiny and counting of votes including cases in which a recount of the votes may be made before the declaration of the result of the election;
  - [(gg) the procedure as to counting of votes recorded by means of voting machines;]
  - (h) the safe custody of 3[ballot boxes, voting machines], ballot papers and other election papers, the period for which such papers shall be preserved and the inspection and production of such papers;
  - [(hh) the material to be supplied by the Government to the candidates of recognised political parties at any election to be held for the purposes of constituting the House of the People or the Legislative Assembly of a State;]
  - (i) any other matter required to be prescribed by this Act.
- [(3) Every rule made under this Act shall be laid as soon as may be after it is made before each House of Parliament while it is in session for a total period of thirty days which may be comprised in one session or [in two or more successive sessions, and if, before the expiry of the session immediately following the session or the successive sessions aforesaid, both Houses agree in making any modification in the rule or both Houses agree that the rule should not be made,] the rule shall thereafter have effect only in such modified form or be of no effect, as the case may be; so, however, that any such

modification or annulment shall be without prejudice to the validity of anything previously done under that rule.].

### **3.2 Conduct of Elections Rules, 1961 (Statutory Rules and Order) with Conduct of Elections (Amendment) Rules, 2013**

#### **Voting by Electronic Voting Machines & EVMs with VVPATs**

##### **49A. Design of Electronic Voting Machines.—**

Every electronic voting machine (hereinafter referred to as the voting machine) shall have a control unit and a balloting unit and shall be of such designs as may be approved by the Election Commission.

**Provided that a printer with a drop box of such design as may be approved by the Election Commission may also be attached to a voting machine for printing a paper trail of the vote, in such constituency or constituencies or parts thereof as the Election Commission may direct.**

##### **49B. Preparation of voting machine by the returning Officer.—**

- (1) The balloting unit of the voting machine shall contain such particulars and in such language or languages as the Election Commission may specify.
- (2) The names of the candidates shall be arranged on the balloting unit in the same order in which they appear in the list of the contesting candidates.
- (3) If two or more candidates bear the same name, they shall be distinguished by the addition of their occupation or residence or in some other manner.
- (4) Subject to the foregoing provisions of this rule, the returning officer shall—
  - (a) fix the label containing the names and symbol of the contesting candidates in the balloting unit and secure that unit with his seal and the seals of such of the contesting candidates or their election agents present as are desirous of affixing the same;
  - (b) set the number of contesting candidates and close the candidate set

section in the control unit and secure it with his seal and the seals of such of the contesting candidates or their election agents present as are desirous of affixing the same;

- (c) where the printer for paper trail is used under the proviso to rule 49A, set the printer as per the number of contesting candidates set in the Control Unit by –
  - i) *loading in the printer the serial numbers and names of candidates and symbols allotted to them as given on the balloting units under clause (a);*
  - ii) *loading paper in the printer; and*
  - iii) *sealing the printer in such manner as may be directed by the Election Commission”.*

**49C. Arrangements at the polling stations.—**

- (1) Outside each polling station there shall be displayed prominently—
  - (a) a notice specifying the polling area, the electors of which are entitled to vote at the polling station and, when the polling area has more than one polling station, the particulars of the electors so entitled; and
  - (b) a copy of the list of contesting candidates.
- (2) At each polling station there shall be set up one or more voting compartments in which the electors can record their votes free from observation.
- (3) The returning officer shall provide at each polling station one voting machine and copies of relevant part of the electoral roll and such other election material as may be necessary for taking the poll.
- (4) Without prejudice to the provisions of sub-rule (3), the returning officer may, with the previous approval of the Election Commission, provide one common voting machine for two or more polling stations located in the same premises.

\* \* \* \* \*



**49E. Preparation of voting machine for poll.—**

- (1) The control unit and balloting unit of every voting machine used at polling station **and the printer for paper trail where used**, shall bear a label marked with—
  - (a) the serial number, if any, and the name of the constituency;
  - (b) the serial number and name of the polling station or stations as the case may be;
  - (c) the serial number of the unit; and
  - (d) the date of poll.
- (2) Immediately before the commencement of the poll, the presiding officer shall demonstrate to the polling agents and other persons present that no vote has been already recorded in the voting machine and it bears the label referred to in sub-rule **(1)**, **and where the printer for paper trail is used that the drop box of the printer is empty.**
- (3) A paper seal shall be used for securing the control unit of the voting machine, and the presiding officer shall affix his own signature on the paper seal and obtain thereon the signature of such of the polling agents present as the desirous of affixing the same.
- (4) The presiding officer shall thereafter fix the paper seal so signed in the space meant therefore in the control unit of the voting machine and shall secure and seal the same.
- (5) The seal used for securing the control unit shall be fixed in such manner that after the unit has been sealed, it is not possible to press the “result button” without breaking the seal.
- (6) The control unit shall be closed and secured and placed in full view of the presiding officer and the polling agents and the balloting unit placed in the voting compartment.

- (7) **Where the printer for paper trail is used, the printer shall also be kept along with the balloting unit in the voting compartment and shall be connected to the EVM in the manner as directed by the Election Commission.**

\* \* \* \* \*

**49L. Procedure for voting by voting machines. —**

- (1) Before permitting an elector to vote, the polling officer shall—
- (a) record the electoral roll number of the elector as entered in the marked copy of the electoral roll in a register of voters in Form 17A.
  - (b) obtain the signature or the thumb impression of the elector on the said register of votes; and
  - (c) mark the name of the elector in the marked copy of the electoral roll to indicate that he has been allowed to vote:
  - (d) give details of the document produced by the elector in proof of his/her identification.]

Provided that no elector shall be allowed to vote unless he has his signature or thumb impression on the register of voters.

- (2) Notwithstanding anything contained in sub-rule (2) of rule 2, it shall be necessary for any presiding officer or polling officer or any other officer to attest the thumb impression of the elector on the register of voters.

**49M. Maintenance of secrecy of voting by electors within the polling station and voting procedures. —**

- (1) Every elector who has been permitted to vote under rule 49L shall maintain secrecy of voting within the polling station and for that purpose observe the voting procedure hereinafter laid down.
- (2) Immediately on being permitted to vote the elector shall proceed to the

presiding officer or the polling officer in-charge of the control unit of the voting machine who shall, by pressing the appropriate button on the control unit, activate the balloting unit; for recording of elector’s vote.

- (3) The elector shall thereafter forthwith—
  - (a) proceed to the voting compartment;
  - (b) record his vote by pressing the button on the balloting unit against the name and symbol of the candidate for whom he intends to vote; and
  - (c) come out of the voting compartment and leave the polling station:

**Provided that where printer for paper trail is used, upon casting the vote by pressing the button under clause (b), the elector shall be able to view through the transparent window of the printer, kept alongwith the balloting unit inside the voting compartment, the printed paper slip showing the serial no, name and the symbol of the candidate for whom he has cast his vote before such paper slip gets cut and drops in the drop box of the printer”.**

- (4) Every elector shall vote without undue delay.
- (5) No elector shall be allowed to enter the voting compartment when another elector is inside it.
- (6) If an elector who has been permitted to vote under rule 49L or rule 49P refuses after warning given by the presiding officer to observe the procedure laid down in sub-rule (3) of the said rules, the presiding officer or a polling officer under the direction of the presiding officer shall not allow such elector to vote.
- (7) Where an elector is not allowed to vote under sub-rule (6), a remark to the effect that voting procedure has been violated shall be made against the elector’s name in the register of voters in Form 17A by the presiding officer under his signature.

#### **49MA Procedure in case of complaint about particulars printed on paper slip-**

- (1) **Where printer for paper trail is used, if an elector after having recorded**

his vote under rule 49M alleges that the paper slip generated by the printer has shown the name or symbol of a candidate other than the one he voted for, the presiding officer shall obtain a written declaration from the elector as to the allegation, after warning the elector about the consequence of making a false declaration.

- (2) If the elector gives the written declaration referred to in sub-rule (1), the presiding officer shall make a second entry related to that elector in Form 17A, and permit the elector to record a test vote in the voting machine in his presence and in the presence of the candidates or polling agents who may be present in the polling station, and observe the paper slip generated by the printer.
- (3) If the allegation is found true, the presiding officer shall report the facts immediately to the returning officer, stop further recording of votes in that voting machine and act as per the direction that may be given by the Returning Officer.
- (4) If, however, the allegation is found to be false and the paper slip so generated under sub-rule (1) matches with the test vote recorded by the elector under sub-rule (2), then, the presiding officer shall-
  - (i) make a remark to that effect against the second entry relating to that elector in Form 17A mentioning the serial number and name of the candidate for whom such test votes has been recorded;
  - (ii) obtain the signature or thumb impression of that elector against such remarks; and
  - (iii) make necessary entries regarding such test vote in item 5 in Part I of Form 17C.

#### 49N. Recording of votes of blind or infirm electors.—

- (1) If the presiding officer is satisfied that owing to blindness or other physical infirmities an elector is unable to recognise the symbol on the balloting unit

of the voting machine or unable to record his vote by pressing the appropriate button thereon without assistance the presiding officer shall permit the elector to take with him a companion of not less than eighteen years of age to the voting compartment for recording the vote on his behalf and in accordance with his wishes: Provided that no person shall be permitted to act as the companion of more than one elector at any polling station on the same day: Provided further that before any person is permitted to act as the companion of an elector on any day under this rule that person shall be required to declare that he will keep secret the vote recorded by him on behalf of the elector and that he has not already acted as the companion of any other elector at any other polling station on that day.

- (2) The presiding officer shall keep a record in Form 14A of all cases under this rule.

**49Q. Presiding Officer’s entry in the voting compartment during poll.—**

- (1) The presiding officer may whenever he considers it necessary so to do, enter the voting compartment during poll and take such steps as may be necessary to ensure that the balloting unit is not tampered or interfered with in any way.
- (2) If the presiding officer has reason to suspect that an elector who has entered the voting compartment is tampering or otherwise interfering with the balloting unit or has remained inside the voting compartment for unduly long period, he shall enter the voting compartment and take such steps as may be necessary to ensure the smooth and orderly progress of the poll.
- (3) Whenever the presiding officer enters the voting compartment under this rule, he shall permit the polling agents present to accompany him if they so desire.

**49R. Closing of poll.—**

- (1) The presiding officer shall close a polling station at the hour fixed in that behalf under section 56 and shall not thereafter admit any elector into the polling station:

Provided that all electors present at the polling station before it is closed shall be allowed to cast their votes.

- (2) If any question arises whether an elector was present at the polling station before it was closed it shall be decided by the presiding officer and his decision shall be final.

**49S. Account of votes recorded.—**

- (1) The presiding officer shall at the close of the poll prepare an account of votes recorded in Form 17C and enclose it in a separate cover with the words 'Account of Votes Recorded' superscribed thereon.
- (2) The presiding officer shall furnish to every polling agent present at the close of the poll a true copy of the entries made in Form 17C after obtaining a receipt from the said polling agent therefore and shall attest it as a true copy.

**49T. Sealing of voting machine after poll.—**

- (1) As soon as practicable after the closing of the poll, the presiding officer shall close the control unit to ensure that no further votes can be recorded and shall detach the balloting unit from the control **unit and from the printer, where printer is also used, so however, that the paper slips contained in the drop box of the printer shall remain intact.**
- (2) The control unit and the balloting unit **and the printer, where it is used,** shall thereafter be sealed, and secured separately in such manner as the Election Commission may direct and the seal used for securing them shall be so affixed that it will not be possible to open the units without breaking the seals.
- (3) The polling agents present at the polling station, who desire to affix their seals, shall also be permitted to do so.

**49U. Sealing of other packets.—**

- (1) The presiding officer shall then make into separate packet,—

- (a) the marked copy of the electoral roll;
  - (b) the register of voters in Form 17A;
  - (c) the cover containing the tendered ballot papers and the list in Form 17B;
  - (d) the list of challenged votes; and
  - (e) any other papers directed by the Election Commission to be kept in a sealed packet.
- (2) Each packet shall be sealed with the seal of the presiding officer and with the seal either of the candidate or of his election agent or of his polling agent who may be present at the polling station and may desire to affix his seal thereon.

**49V. Transmission of voting machines, etc., to the returning officer.—**

- (1) The presiding officer shall then deliver or cause to be delivered to the returning officer at such place as the returning officer may direct,—
- (a) the voting machine;
  - (b) the account of votes recorded in Form 17C;
  - (c) the sealed packets referred to in rule 49U; and
  - (d) all other papers used at the poll. 80
- (2) The returning officer shall make adequate arrangements for the safe transport of the voting machine, packets and other papers for their safe custody until the commencement of the counting of votes.

**49X. Closing of voting machine in case of booth capturing.—**Where the presiding officer is of opinion that booth capturing is taking place at a polling station or at a place fixed for the poll, he shall immediately close the control unit of the voting machine to ensure that no further votes can be recorded and shall detach the balloting that from the control unit.]

**49W. Procedure on adjournment of poll.—**

- (1) If the poll at any polling station is adjourned under sub-section (1) of section 57, the provision of rules 49S to 49V shall, as far as practicable, apply as if the poll was closed at the hour fixed in that behalf under section 56.
- (2) When an adjourned poll is recommended under sub-section (2) of section 57, the electors who have already voted at the poll so adjourned shall not be allowed to vote again.
- (3) The returning officer shall provide the presiding officer of the polling station at which such adjourned poll is held, with the sealed packet containing the marked copy of the electoral roll, register of voters in Form 17A and a new voting machine.
- (4) The presiding officer shall open the sealed packet in the presence of the polling agents present and use the marked copy of the electoral roll for marking the names of the electors who are allowed to vote at the adjourned poll.
- (5) The provisions of rule 28 and rules 49A to 49V shall apply in relation to the conduct of an adjourned poll before it was so adjourned.

**66A. Counting of votes where electronic voting machines have been used.—**

In relation to the counting of votes at a polling station, where voting machine has been used,—

- (i) the provisions of rules 50 to 54 and in lieu of rules 55, 56 and 57, the following rules shall respectively apply, namely:—

'55C. Scrutiny and inspection of voting machines.—

- (1) The returning officer may have the control units of the voting machines used at more than one polling station taken up for scrutiny and inspection and votes recorded in such units counted simultaneously.
- (2) Before the votes recorded in any control unit of voting machine are counted under sub-rule (1), the candidate or his election agent or his counting agent present at the counting table shall be allowed to inspect the paper seal and



such other vital seals as might have been affixed on the unit and to satisfy themselves that the seals are intact.

- (3) The returning officer shall satisfy himself that none of the voting machines has in fact been tampered with.
- (4) If the returning officer is satisfied that any voting machine has in fact been tampered with, he shall not count the votes recorded in that machine and shall follow the procedure laid down in section 58, or section 58A or section 64A, as may be applicable in respect of the polling station or stations where that machine was used.

**56C. Counting of votes.—**

- (1) After the returning officer is satisfied that a voting machine has in fact not been tampered with, he shall have the votes recorded therein counted by pressing the appropriate button marked “Result” provided in the control unit whereby the total votes polled and votes polled by each candidate shall be displayed in respect of each such candidate on the display panel provided for the purpose in the unit.
- (2) As the votes polled by each candidate are displayed on the control unit, the returning officer shall have,—
  - (a) the number of such votes recorded separately in respect of each candidate in Part II on Form 17C;

**Provided that the test vote recorded, if any, for a candidate, as per item 5 in Part I of Form 17C, shall be subtracted from the number of votes recorded for such candidate as displayed on the control unit.**

- (b) Part II of Form 17C completed in other respects and signed by the counting supervisor and also by the candidates or their election agents or their counting agents present; and
- (c) corresponding entries made in a result sheet in Form 20 and the particulars so entered in the result sheet announced.

**“56D Scrutiny of paper trail-**

- (1) Where printer for paper trail is used, after the entries made in the result sheet are announced, any candidate, or in his absence, his election agent or any of his counting agents may apply in writing to the returning officer to count the printed paper slips in the drop box of the printer in respect of any polling station or polling stations.**
- (2) On such application being made, the returning officer shall, subject to such general or special guidelines, as may be issued by the Election Commission, decide the matter and may allow the application in whole or in part or may reject in whole, if it appears to him to be frivolous or unreasonable.**
- (3) Every decision of the returning officer under sub-rule (2) shall be in writing and shall contain the reasons therefor.**
- (4) If the returning officer decides under sub-rule (2) to allow counting of the paper slips either wholly or in part or parts, he shall-**

  - (a) do the counting in the manner as may be directed by the Election Commission;**
  - (b) if there is discrepancy between the votes displayed on the control unit and the counting of the paper slips, amend the result sheet in Form 20 as per the paper slips count;**
  - (c) announce the amendments so made by him; and**
  - (d) complete and sign the result sheet.”**

**57C. Sealing of voting machines.—**

- (1) After the result of voting recorded in a control unit has been ascertained candidate-wise and entered in Part II of Form 17C and Form 20 under rule 56C, the returning officer shall reseal the unit with his seal and the seals of such of the candidates or their election agents present who may desire to affix the seals thereon so however that the result of voting recorded in the**

unit is not obliterated and the unit retains the memory of such result **and where printer for paper trail is used, the returning officer shall seal the paper slips in such manner, as may be directed by the Election Commission.**

- (2) The control unit and the paper slips so sealed shall be kept in specially prepared boxes on which the returning officer shall record the following particulars, namely:—
- (a) the name of the constituency;
  - (b) the particulars of polling station or stations where the control unit has been used;
  - (c) serial number of the control unit and printer wherever used;
  - (d) date of poll; and
  - (e) date of counting’;
- (ii) the provisions of rules 60 to 66 shall, so far as may be, apply in relation to voting by voting machines and any reference in those rules to,—
- (a) ballot paper shall be construed as including a reference to such voting machine; 91
  - (b) any rule shall be construed as a reference to the corresponding rule in Chapter II of Part IV or, as the case may be, to rule 55C or 56C or 57C].

**92. Custody of ballot boxes and papers relating to election-**

- (1A) All voting machines used at an election shall be kept in the custody of the concerned district election officer.
- (2) The district election officer shall keep in safe custody-

\* \* \* \* \*

**(cc) the printed paper slips sealed under the provisions of rule 57C.**

\* \* \* \* \*

**(dd) The packets containing registers of voters in Form 17A**

**[93. Production and inspection of election papers.—**

(1) While in the custody of the district election officer or, as the case may be, the returning officer—

- (a) the packets of unused ballot papers with counterfoils attached thereto;
- (b) the packets of used ballot papers whether valid, tendered or rejected;
- (c) the packets of the counterfoils of used ballot papers;
- (cc) the printed paper slips sealed under the provisions of rule 57C.
- (d) the packets of the marked copy of the electoral roll or, as the case may be, the list maintained under sub-section (1) or sub-section (2) of section 152; and

[(dd) the packets containing registers of voters in form 17-A;]

(e) the packets of the declarations by electors and the attestation of their signatures; shall not be opened and their contents shall not be inspected by, or produced before, any person or authority except under the order of a competent court.

[1A) The control units sealed under the provisions of rule 57C and kept in the custody of the district election officer shall not be opened and shall not be inspected by, or produced before, any person or authority except under the orders of a competent court.]

(2) Subject to such conditions and to the payment of such fee as the Election Commission may direct, —

- (a) all other papers relating to the election shall be open to public inspection; and
- (b) copies thereof shall on application be furnished.

- (3) copies of the returns by the returning officer forwarded under rule 64, or as the case may be, under clause (b) of sub-rule (1) of rule 84 shall be furnished by the returning officer, district election officer, chief electoral officer or the Election Commission on payment of a fee of two rupees for each copy.]

**94. Disposal of election papers.—**

Subject to any direction to the contrary given by the Election Commission or by a competent court or tribunal—

[(a) the packets of unused ballot papers shall be retained for a period of six months and shall thereafter be destroyed in such manner as the Election Commission may direct;]

[(aa) the voting machines kept in the custody of the district election officer under sub-rule (1A) of rule 92 shall be retained intact for such period as the Election Commission may direct and shall not be used at any subsequent election without the previous approval of the Election Commission;]

(b) the other packets referred to in sub-rule (1) of rule 93 shall be retained for a period of one year and shall thereafter be destroyed:

[Provided that packets containing the counterfoils of used ballot papers and the printer paper slips, if any, shall not be destroyed except with the previous approval of the Election Commission;]

(c) all other papers relating to the election shall be retained for such period as the Election Commission may direct.

**95. Power of the Election Commission to issue directions.—**

Subject to the other provisions of these rules, the Election Commission may issue such directions as it may consider necessary to facilitate the proper use and operation of the voting machines.

[For provisions regarding use of VVPAT system please refer to the Conduct of Elections (Amendment) Rules, 2013 reproduced in Chapter 22]

## CHAPTER – 4

### STORAGE OF EVMs AND OPENING OF EVM-WAREHOUSE

#### 4.1 During Non-Election Period

Non-election period means, after EP period (i.e. 45-days from the date of declaration of the result of the last election) and upto announcement of next election in the constituency.

##### 4.1.1 Physical Verification of EVMs

During non-election period, 100% physical verification of EVMs shall be carried out by the District Election Officers (DEOs) in the month of April every year so that the report of the same is made available to the Commission through the Chief Electoral Officer of the concerned States/UTs by 15th May every year. For this purpose, the Commission will issue a direction for opening of EVM-warehouses. On receiving direction from the Commission, the DEOs shall take the following course of action:-

- a) CEO/DEO shall ensure that EVM-warehouses, in which EVMs pertaining to any election petition or court cases are stored, shall not be opened for the purpose of physical verification of EVMs.
- b) DEO shall nominate an Officer not below the rank of Tehsildar for the purpose of opening of EVM-warehouse [except EVM-warehouse mentioned at (a) above] and for conducting physical verification of EVMs.
- c) National and State recognized political parties shall be informed in writing, at least 24 hours in advance, about the date and time of opening and closure of EVM warehouse. Their authorized representatives shall be allowed to remain present at the time of opening and closure of the warehouse. A report shall be prepared in this regard and signature of the authorized representatives of political parties shall also be taken on the report.
- d) Details of EVMs shall be maintained in a Master Stock Register (MSR). MSR shall be maintained warehouse-wise for every district in the format given in **Annexure –1**.

- e) Based on this MSR, the DEO shall send a physical verification report in the format given in Annexure - 2 to the Commission through the CEO of the concerned States/UTs.

#### **4.1.2 Storage of EVMs**

- i. EVM should be stored in Treasury, wherever possible.
- ii. Where not stored in the Treasury, EVMs must be stored in a separate warehouse where nothing other than EVM is kept.
- iii. Normally the EVMs should be stored at District Head Quarters.
- iv. However, if it is not possible to store the EVMs at District HQs, then EVM storage warehouse should not be at a place below Tehsil headquarters.
- v. No EVM shall be kept outside the EVM warehouse (i.e. all the EVMs should be kept in EVM warehouse and not at any other place) for any purpose without specific approval of the Commission
- vi. EVM storage warehouse must not have more than one (1) entry point. If there are any other doors or windows in the warehouse, they should be sealed using brick-masonry or concrete.
- vii. Entry of EVM storage warehouse must be secured by a double lock system, which should be held jointly by two separate officers, to be nominated by the DEO. One of whom shall not be below the rank of Tehsildar.
- viii. Warehouse must be free from dampness, pests, rodents etc. Proper fire-fighting arrangement must be made available. Warehouse should be free from flood/water logging risk/cracks/leakage/broken window etc. To provide an inlet/outlet for air-circulation to avoid foul smell in strong rooms, exhaust fan may be installed, subject to the following conditions:-
  - a) Exhaust fan shall be installed on the front side of the strong room, where security guards are posted and not on the rear side;

- b) Exhaust fan shall be installed at the highest point feasible, below the roof;
  - c) A strong iron grill shall be installed at the vent/passage where exhaust fan will be installed.
  - d) EVMs must be kept in a safe manner.
- ix. Adequate security arrangement must be made at warehouse by deputing police/security guard round the clock.

#### **4.1.3 Movement of EVMs**

During non-election period, EVMs shall not be moved in or out of the EVM warehouse without specific approval of the Commission.

In case of intra or inter State shifting of EVMs, on the direction of the Commission, the following shall be strictly followed:-

- i. The CEO will communicate the direction of the Commission on shifting of EVMs to the DEO concerned.
- ii. DEO(s) will issue written order to the officer referred in para 4.1.1(b) above for opening of EVM-warehouse [except EVM-warehouse mentioned at [4.1.1(a)] to shift the required number of EVMs.
- iii. On receiving the written order of the DEO, the nominated Officer shall identify the EVMs to be moved out and make an entry of the details of such EVMs in the Master Stock Register/Movement Register and shall take a written acknowledgement from the officer, who is receiving the EVM, as proof of having received the EVMs.

## **4.2 During Election Period**

### **4.2.1 Physical Verification of EVMs**

If there is a general election during the year, the DEO shall carry out 100% physical verification of EVMs during the First Level Checking of the EVMs and send the report to the Commission through Chief Electoral Officer in the format in **Annexure –3**.



## 4.2.2 Storage of EVMs

### 4.2.2.1 Pre-Poll Storage:

After FLC and first randomization of EVMs, EVMs shall be handed over to the Returning Officer/Assistant Returning Officer concerned. The Returning Officers shall follow the following guidelines:-

- i) RO/ARO shall store the EVMs, allocated for his constituency, in a strong room in the presence of representatives of National/State Level Political Parties, under videography. EVMs meant for training and awareness of voters shall be kept in a separate strong room so that strong room having EVMs (including reserve EVMs) meant for poll need not be opened before preparation of EVMs.
- ii) Thereafter, RO shall open the strong room having EVMs (including reserve EVMs) meant for poll at the time of preparation of EVMs (candidate setting) in the presence of candidates/their representatives, under videography.
- iii) After preparation of EVMs at RO level, EVMs including reserve EVMs shall again be kept in strong room in the presence of candidates/their representatives, under videography.
- iv) Thereafter, RO shall open the strong room having EVMs (including reserve EVMs) on the day of dispersal of polling parties in the presence of candidates/their representatives, under videography.
- v) After completion of poll, polled EVMs shall be escorted back to the strong room for storing in double lock system in the presence of candidates/their representatives, under videography.

### 4.2.2.2 Post-Poll Storage:

The following instructions shall be strictly followed for the security and safety of strong rooms where the polled EVMs are kept for counting of votes –

- i) The strong rooms should have double lock system. One key should be kept with District Election Officer and the other with Returning Officer of concerned assembly constituency.

- ii Two cordoned security arrangements should be made round the clock for the strong rooms having polled EVMs kept for counting of votes. The CPF should man the innermost perimeter security immediately outside the strong room and the State Armed Police should man the outermost perimeter security.
- iii All contesting candidates should be intimated in writing to depute their representatives to keep a close watch on security arrangement of strong room. They should be allowed to stay outside the inner perimeter at a location, which enables them to view the entry points of the strong room. As far as possible, facilities such as proper shade, drinking water, etc. shall be provided to them. If there is no direct view to the entry point of the strong room, CCTV may be arranged at such location, from where they can see the strong room door on CCTV. In such a case, they may be taken periodically to the inner perimeter in batches, to see, verify and satisfy themselves regarding the security of strong room. The CCTV display of Strong Room shall be arranged on a large TV screen at the place earmarked for the representatives of Political Parties and agents of the candidates, so that they can continuously monitor the Strong Room.
- iv A control room adjacent to the strong room SHOULD BE operative round the clock.
- v A Gazetted officer along with a senior police officer should be put on duty round the clock for monitoring the security arrangements of strong room.
- vi There should be sufficient arrangement of fire extinguishers near and inside the strong room.
- vii There should be an arrangement round the clock for the security of unused EVMs also.
- viii No one should be allowed to enter the inner perimeter without adhering the following protocols:-

- a) The log book shall be maintained by the CPF in which entry should be made about date, time, duration and name(s) of person(s) crossing the second security ring i.e. the middle perimeter. This includes visits by the Observers or DEOs or SPs or candidates or their agents or any other person.
  - b) Video cameras should be provided to the CPF contingent to record all visits made by such visitors.
- ix It should be ensured that there is uninterrupted power supply at the strong room locations during the entire period wherein EVMs are stored. CEO may address the Chairman of Electricity Board concerned separately regarding this. Local Electricity Board officials should be asked to ensure the same. Contingency arrangement of stand-by generators should be made to ensure uninterrupted power supply.
  - x The phone nos. of CEO, Addl. CEOs, DEC in-charge in the ECI and the DEO/SP/COP/ROs concerned should be given to the candidates, who may provide the same to their representatives, keeping vigil at the strong room location(s). The candidates may advise their representatives to contact the officials, in case of any emergency.
  - xi All the entry points (doors etc.) of strong rooms should be under constant videography using the web-cams and laptops available. If there are other doors of the strong room, they should also be covered by the web-cams/videography. Persons coming to take back-up from the laptops should have identity cards given to them and their names should be recorded in advance with the CPF contingent stationed there. Their visits should be videographed by the CPF contingent with the video camera provided for the entire duration.
  - xii Returning Officers should visit the storage campus (upto the inner perimeter only) every day in the morning and evening and check the log book and videography and send a report to the DEO on the status

every day. In case of strong rooms located in the district headquarters, the DEO should do the same. Where the strong rooms are situated outside the District Headquarters, DEO should visit the same as frequently as possible and at least once in 3 to 4 days.

- xiii No vehicle, including that of any official or ministers or any other political functionary, should be allowed inside the secured campus where the EVMs are stored. Alighting point for the vehicles should be marked clearly ahead of the outer security perimeter itself beyond it, it should be a pedestrian zone only.
- xiv DCs and SPs shall be personally responsible for security of strong room within the district and meticulous implementation of the protocol. The copy of this Manual should be made available to all candidates, DEOs, ROs and CPF commandant.
- xv On the day of counting of votes, the strong room shall be opened in the presence of candidates/their representative, RO and Observer under videography.
- xvi After completion of counting of votes, Control Units shall be sealed as per existing instruction of the Commission. Thereafter, EVMs (Balloting Units and Control Units) shall be shifted back to Strong Room for safe storage.

### Note:

#### 1. Procedure to be followed for storing polled EVMs in strong room

- (i) All Presiding Officers or the Collecting Parties should deposit the voting machines and election papers and materials at the storage centres without any avoidable delay. Any officer who defaults in this respect will make himself liable to disciplinary action.
- (ii) Returning Officer may earmark inside the storage room or building, specified parts of the floor space in the form of squares in advance for stacking the voting machines received from particular polling stations. The arrangement for this should follow the serial number of polling stations.

- (iii) All Balloting unit(s) and control unit received from one polling station must invariably be kept together at one place on the same square. The control unit should be kept on top of the Balloting unit(s). One copy of the Part I of Form-17 C, as filled by the concerned Presiding Officer of each polling station, should be kept on top of the control unit pertaining to the polling station. Sealed envelope containing the declarations made by the Presiding Officers before the start of the poll and at the end of the poll should also be kept in the strong room with polled EVMs. The duplicate copy of the account of votes recorded and the paper seal account should be kept under your safe custody along with the Presiding Officers Diary and other records like Register of Voters(17A), reports of Sector/Zonal magistrates, Additional inputs provided by the Presiding Officer (refer ECI instruction in this regard) etc. Under no circumstance, these papers/records should be put in strong room where polled EVMs are kept.
- (iv) Sufficient space should be left between rows of voting machines as they are being stacked so that other machines received subsequently out of turn (from the point of view of serial numbers of the polling stations) may be kept at their appropriate allotted space without the necessity of having to shift any of the voting machines received and stacked in earlier point of time.
- (v) If any of the contesting candidates so desires, he may be permitted to post an agent to keep watch at the place where the voting machines are stored pending the counting and allow him to affix his own seals to the doors and windows of the building in which voting machines have been stored in addition to the seals that may be affixed by you. It should also be ensured that immediately after all the voting machines have been received and stored, the room is locked forthwith. Thereafter, no one is allowed to go in until the morning of the day fixed for counting. If during this interval, for some unavoidable reason, the room has to be opened you should send for the candidates or their authorized representatives by giving them intimation in writing and open the room in their presence and immediately after the purpose for which the room is opened is over, this room should be closed and sealed and the candidates or their representatives should again be allowed to put their seal on the door lock and windows.
- (vi) Whenever it is necessary to open the room in which the voting machines are stored,

proper entries should be made in the logbook giving details of the persons entering the room, the purpose of such entry, time of entry, time of exit, signature of the guards, etc.

- (vii) These instructions will also apply mutatis mutandis to the storage of the voting machines during the interval between the original count and the recount, if any

**2. Under rule 94(aa) of the Conduct of Elections Rules 1961, the guidelines of the Commission on retention period of the EVMs after using in election and for using the same in the subsequent elections, are as under:**

- A. Every Voting Machine (EVM) used in an election and kept in the custody of the District Election Officer shall be kept untouched, under the standard protocol of security, till confirmation of Election petition position from the High Court concerned after the completion of the period for filing Election Petition i.e. 45 days from the date of declaration of the result.
- B. In the case of elections, where no election petition has been filed or no other court cases are pending, after the aforesaid period, the EVMs may be allowed to be used by the Election Commission for any future election or any other purpose like movement, physical verification of EVMs, etc.
- C. In case of any election where election petition has been filed, the following action shall be taken:-
- (i) If the EVMs are the subject of the election petition, the EVMs used at all Polling Stations in the constituency concerned shall continue to be kept in the safe custody of the District Election Officer, till such time the Election Petition is finally disposed of by the Courts.
- (ii) If the EVMs are not the subject of the election petition, an application may be moved to the concerned Court for allowing the EVMs concerned to be taken out of the strong room for any future election or any other purpose like movement, physical verification of EVMs etc.
- (iii) In case EVMs not involved in any Election Petition/Court Case are stored with the EVMs involved in Election Petition/Court Case, the

following procedure shall be followed for segregating the EVMs not involved in any election petition/court case from the EVMs involved in EP/Court case:-

- (a) A Notice informing the opening of Strong Room having EVMs involved in EP/Court Case shall be given to the petitioners/respondents of the EP/Court Case and the representatives of all political parties in writing at least 72 hours in advance, requesting them to remain present at the time of opening of strong room.
  - (b) The strong room shall be opened in the presence of the District Election Officer, Petitioners/respondents of the EP/Court case and representatives of Political Parties.
  - (c) The EVMs not involved in any EP/Court Case shall be segregated from the EVMs involved in EP/Court Case for taking out of the strong room. A list of EVMs being so taken out from the strong room shall be prepared.
  - (d) The EVMs, which are not involved in any EP/Court Case, should alone be taken out of the Strong room.
  - (e) The entire process shall be videographed.
  - (f) A copy of the list of EVMs being taken out from the strong room and copy of videography shall be given to the petitioner/respondent of the EP/court case and acknowledgement taken.
- D. If any other Court Case is pending, like, booth capturing, etc., in which any EVM is involved, the EVM concerned or the EVM(s) used at such Polling Station(s) concerned may also be kept till the final disposal of the said case.

After the final disposal of the election petitions or other court cases, as the case may be, referred to above, the EVMs can be used for subsequent elections.

\*\*\*\*\*

## CHAPTER – 5

### FIRST LEVEL CHECKING OF EVMs (FLC)

#### 5.1 FLC when to be done:

FLC of EVMs shall be done before every bye-election and General Election. It will be done sufficiently in advance so that all checks are carried out without any undue haste in the presence of representatives of political parties. FLC of EVMs shall be completed, in any case, well before finalization of the list of contesting candidates in an election. the issue of notification calling the election.

#### 5.2 FLC to be done in the presence of representatives of political parties:

Depending on the number of EVMs to be checked in FLC, the DEO shall prepare a schedule for the FLC of EVMs in consultation with the EVM manufacturers (ECIL & BEL) and the CEO. The schedule will be made in such a manner that sufficient time is available for FLC of EVMs by engineers of manufacturers. The schedule for FLC shall be communicated to every national and state level recognized political party in writing by the DEO at least one week before the beginning of the FLC in the district. On the day of the FLC, representatives of all national and state level recognized political parties authorized by the District President of the party shall be allowed to be present. A register shall be kept by the DEO in Annexure –4 in which signatures of all political parties shall be taken every day as token of their presence.

#### 5.3 Arrangements in the premises of FLC:

FLC shall be carried out in a large hall which can accommodate EVMs to be checked. The hall should be able to accommodate officers nominated by the DEO, engineers of BEL and ECIL and also representatives of political parties. Before the hall is used for FLC, it shall be fully sanitized to ensure that the hall is free from any other electronic device or components of electronic devices. Every entry to the hall shall be guarded by police force. Every hall shall have a door frame, metal detector. Every person who enters the hall shall be frisked at every entry. Entry to this hall shall be on production of Identity Card of the authorized officials/passes issued by the District Election Officer. Nobody will be allowed to carry any electronic device inside



the hall including cell phones, camera and spy pens etc.. Similarly, nobody will be allowed to carry anything out of the FLC hall.

#### 5.4 Manpower in FLC:

FLC shall be carried out only by authorized engineers of BEL and ECIL. BEL and ECIL shall be fully responsible for the integrity, efficiency and competence of their engineers. List of engineers deputed by BEL and ECIL for carrying out FLC in a district alongwith their identity card numbers etc. shall be communicated in writing by BEL and ECIL to the DEO. No engineers, technicians or other technical staff except authorized engineers/technical staff of BEL and ECIL shall be allowed to enter the FLC hall. Authorized persons will be allowed to enter the FLC hall only after proper identification using photo identity documents.

#### 5.5 Work to be done during FLC:

At the time of FLC, the following shall be done:-

Removal of address tags, Ballot Papers, cleaning of superscriptions on CU & BU, clearing of earlier poll data, dusting of CU & BU etc. These activities are carried-out in the secured place/protected place provided by the District Election Officers.

**Visual Inspection of CU/BU:** Physical verification of Carrying Cases, Control Unit, Balloting Unit, Connecting Cable, Connector, Latches etc. to ensure no breakages.

**Full functionality checks:** Checking of all switches in Control Unit & Balloting Unit, doors (flaps), sealing provisions, scratches on acrylic screen etc. Response of all switches, confirmation tests for efficacy of Control Unit, Balloting Unit etc. –BEL and ECIL engineers shall carry out test prescribed by the manufacturers to confirm that all components of the EVM are original. The plastic cabinets of both Control Unit and Balloting Unit of the EVMs shall be opened by the BEL/ECIL engineers in the presence of political party representatives at the time of FLC and the PCB and other components of EVMs will be shown to them. BEL and ECIL engineers will certify in **Annexure-5** that all the components of the EVMs are original. If any EVM is found to be defective, it will be kept aside and then taken to the factory of BEL and ECIL for repairs. No repair of the machine shall be carried out in the field. Changing of components of the machines in the field is strictly prohibited. Detailed

step-by-step instructions of checking of the machine shall be issued separately by BEL and ECIL for their respective machines. These instructions will include a list of equipment, which the engineers will be required to carry with them in FLC hall. Security personnel will not allow any other equipment to be carried into the FLC hall.

**Conduct of Mock Poll:** Casting of votes against all 16 candidate switches, observation of result & clearing of mock poll data will be done for each EVM. In 5% percent of EVMs at least 1000 votes shall be polled during the mock poll. In rest of the machines number of votes polled during the mock poll should be to the satisfaction of the representatives of political parties. Representatives of political parties shall be allowed to do the mock poll themselves. Signatures of representatives of political parties shall be taken in a register in **Annexure –6** as a token of having done mock poll themselves.

**Demonstration of printout of results:** A printout of the results of mock poll as well as a sequential print out of every vote polled during the mock poll shall be taken out for at least 10% of EVMs and shown to the representatives of political parties. Representatives of political parties shall be allowed to pick machines randomly for this purpose. Signatures of representatives of political parties shall be taken in a register in **Annexure-7** as a token of having seen the print out and confirm that there is no discrepancies between the votes polled during the mock poll and results in the print out.

## 5.6 Sealing of plastic cabinet of Control Unit of EVMs with pink paper seal:

In order to ensure that the Control Unit of the EVM cannot be opened after First Level Checking of the EVMs, the Control Unit shall be sealed with the 'Pink Paper Seal' supplied by the Nasik Security Press in the presence of the representatives of the Political Parties present at the time of FLC. The Pink Paper Seal shall be affixed on the portion between the Candidate Set Section and the Result Section of the Control Unit.

After fixing the Pink Paper Seal, the Engineer of the Manufacturer shall put his signature on the Pink Paper Seal; the representatives of the Political Parties shall also be allowed to put their signature on the said seal with party name in abbreviation below the signature. The representatives of the Political Parties present should be

allowed to note down the serial number of the pink paper seal affixed on the Control Unit. A register in **Annexure-8** shall be maintained to note down the serial number of the pink paper seal used on the Control Unit by clearly mentioning the unique ID number of Control Unit and the Pink Paper Seal number. Signatures of representatives of political parties will also be obtained on this register. Photocopy of this register will be given free of cost to all National and State level recognized political parties as soon as FLC is over. Photocopy of this register will also be given to all contesting candidates as soon as last date of withdrawal of candidature is over. Photocopy of this register should also be available at the time of candidate setting and at the time of counting, and should be shown to candidates and their representative and acknowledgement taken on the register.

### **5.7 Supervision of FLC:**

The DEO shall nominate one officer not below the rank of Additional District Magistrate to supervise the entire process of FLC. This officer shall be present in the FLC hall for the entire duration of FLC. The process of FLC shall be continuously videographed. Video CD will be kept in the custody of DEO. CCTV cameras shall be put in the FLC hall in such a manner that the process of FLC can be seen on CCTV in the office of DEO.

### **5.8 Security measures for EVMs after FLC of EVMs:-**

- 5.8.1 Security arrangements should be made round the clock for the strong rooms having EVMs after First Level Checking.
- 5.8.2 The entry point of strong room having EVMs after FLC shall have CCTV coverage round the clock.
- 5.8.3 There should be sufficient arrangement of fire extinguishers near and inside the strong room.

A log book shall be maintained by the security personnel in which entry should be made about date, time, duration and name(s) of anyone entering near the strong rooms. This includes visits by the Observers or DEOs or SPs or Political Parties/candidates or their agents or any other person.

\*\*\*\*\*

## CHAPTER – 6

### FIRST RANDOMIZATION OF EVMs

#### 6.1 Process of First Randomization –

First randomization of Balloting Units (BUs) and Control Units (CUs) will be done to randomly assign EVMs to Assembly Constituencies (ACs), training and Awareness Programmes. After FLC is over, the DEO will fix a schedule for first randomization of EVMs. This schedule should be fixed in such a manner that first randomization is completed before the start of training of polling personnel. During first randomization, CUs and BUs are assigned to ACs in the presence of the representatives of recognized political parties. The randomization will be done in such a way that the CUs and BUs are randomly selected by grouping them to match the poll day requirement including the reserve required for each constituency. Surplus CUs and BUs after assigning ACs to them shall also be randomly grouped and distributed AC wise for the purpose of training and awareness programme. (for the training of the polling staff as well as for the purpose of voter awareness). A sticker of Green colour shall be affixed on the CUs and BUs assigned to ACs for polling. A sticker of Yellow colour shall be affixed on the CUs and BUs assigned for training and awareness programme. The sticker shall clearly indicate the Name of State/UT and the Number and Name of Assembly Constituency. "Training/Awareness" will be written on the sticker of CUs and BUs assigned for training and awareness. "Election" will be written on the sticker of CUs and BUs assigned for polling. No current ID will be given during randomization. After randomization the CUs and BUs will be marked "Election" or "Training/Awareness" in the EVM tracking software.

#### 6.2 Communication of the List of Randomized CUs and BUs to Political Parties

After first randomization list of randomized CUs and BUs clearly indicating which CUs and BUs are to be used in which AC for polling and which CUs and BUs are to be used in which AC for training and awareness should be given to each recognized political party and a written acknowledgement obtained. A copy of this list should be given to all the candidates after the last date of withdrawal of candidatures.

### 6.3 Taking charge of EVMs by RO

After first randomization the R.O of the constituency, shall take charge of the CUs and BUs randomly allotted to his constituency. The CUs and BUs meant for use at the election shall be separately taken to R.O’s strong room under proper escort and will be guarded 24X7. The training EVMs shall be distributed to the relevant officers for the training purpose. At the time of sealing the strong room, the representatives of political parties can remain present and they can also affix their seal on the lock.

### 6.4 Security Measures

- 6.4.1 After first randomization of EVMs the Returning Officer of the constituency, shall take charge of the CUs and BUs randomly allotted to his constituency. The CUs and BUs meant for use at the election shall be separately taken to R.O’s strong room under proper escort and will be guarded 24X7. The training EVMs to be distributed to the relevant officers for the training purpose shall be kept in separate strong room within the same premises. At the time of sealing the strong room, where EVMs to be used for election are kept, the representatives of political parties can remain present and they can also affix their seal on the lock. For this purpose recognised National & State Level Political Parties should be intimated in writing in advance.
- 6.4.2 The strong rooms should have only one entry point and double lock system. One key should be kept with Returning Officer and the other with Assistant Returning Officer of concerned assembly constituency. Other entry points of the strong rooms (including windows) should be sealed in such a way that no one has access inside the strong rooms.
- 6.4.3 Security arrangements should be made round the clock for the strong rooms having EVMs after First Level Checking.
- 6.4.4 The entry point of strong room having EVMs after FLC shall have CCTV coverage round the clock.
- 6.4.5 There should be sufficient arrangement of fire extinguishers near and inside the strong room.

A log book shall be maintained by the security personnel in which entry should be made about date, time, duration, purpose and name(s) of anyone entering near the strong rooms. This includes visits by the Observers or DEOs or SPs or Political Parties/candidates or their agents or any other person.

\*\*\*\*\*

## CHAPTER – 7

### SECOND RANDOMIZATION OF EVMs

#### 7.1 Second randomization

Second randomization of EVMs has to be done before preparation of EVMs for poll by candidate setting as the address tag of EVM is sealed at the time of preparation of EVM (Candidate Set). The purpose of second randomization of EVMs is to allocate EVMs randomly to polling stations. The Returning officer should fix the date of preparation of EVMs for poll (Candidate set) and intimate all candidates to remain present or send their representatives during the process. The date should be fixed as early as possible after the last date of withdrawal of candidatures and finalization of ballot papers. On this day, second randomization should be done before doing the process of preparation of EVMs for polls and CUs and BUs should be randomly allocated to polling stations. After second randomization, Polling Station number should be marked in the EVM tracking software, against those BUs and CUs which have been assigned polling stations. Those BUs and CUs which have not been assigned polling stations but are meant to be used in elections should be marked “Reserve” in the EVM tracking software. A list of CUs and BUs along with the number of polling stations assigned to them should be given to all the candidates. Similarly a list of CUs and BUs kept in reserve should also be given to the candidates and their written acknowledgement taken.

#### 7.2 Allocation of additional BUs

Where more than one Balloting Unit is being used, the Returning Officers will ensure that the additional prepared Balloting Units are also allocated randomly to the polling stations. For this purpose there may be two Scenarios –

##### 7.2.1 Scenario 1 :

Preparation of EVMs and second level randomization is already over before the additional Balloting Units reach the Returning Officer’s Headquarters. In this case, another randomization for allocating Balloting Units No.2/3 will be done to allocate the Balloting Units to the polling stations and the list of such allocation shall also be supplied to the Political Parties/Candidates.

### 7.2.2 Scenario 2:

Preparation of EVMs and second level randomization is done after the arrival of additional Balloting Units. In such case, the randomization will be done in such a way that against the polling station number the Control Unit number is shown first and then the Balloting Unit No.1 and Balloting Unit No2 and so on.

## 7.3 Cascading of BUs

In the constituencies where additional Balloting Units are being used because of the number of contesting candidates being more than 16 (including NOTA), the Presiding Officers should be specifically instructed to arrange the Balloting Units in the manner as shown in the figure enclosed herewith at Annexure-9. For this purpose, the size of Voting Compartment should be increased proportionally in such a way that the electors are not put to any kind of inconvenience and at the same time the secrecy of ballot is not compromised in any way.

\*\*\*\*\*



## CHAPTER – 8

### PREPARATION OF EVMs (CANDIDATE SET)

#### 8.1 When preparation of EVMs to be done

Preparation of EVMs for elections shall be done invariably in the presence of candidates or their representatives. The Returning Officer shall draw a schedule for preparation of EVMs. Preparation of EVMs should start as soon as possible after the last date of withdrawal of candidatures. Sufficient time should be provided for preparation of EVMs for each Assembly Constituency in the case of Assembly Elections and for each assembly segment in the case of Parliamentary Elections. It may be noted that the time required for preparation of EVMs under the new instructions will be sufficiently more than the time required earlier. Therefore, the schedule should be fixed in such a manner that preparation of EVMs is not done in a hurried manner. Ideally, the Returning Officer should fix between 3-5 days for each assembly segment for this purpose. In case of Parliamentary Elections, preparation of EVMs for assembly segment should be supervised by Assistant Returning Officers. The schedule should be made in such a manner that preparation of EVMs is done for all the assembly segments in separate halls and is completed at least 8 – 10 days before the poll. Candidates should be informed in writing of the schedule for preparation of EVMs and should be requested to be present or send their representatives at the time of preparation of EVMs. On the day of the preparation, a register in **Annexure-10** will be kept by the Returning Officer in which the signatures of candidates or their representatives will be taken as token of their presence.

#### 8.2 Arrangements in the premises of preparation of EVM

Preparation shall be carried out in a large hall which can accommodate all EVMs to be prepared. The hall should be able to accommodate officers nominated by the District Election Officer, engineers of Bharat Electronics Limited (BEL) / Electronics Corporation of India Limited (ECIL) and also representatives of candidates. Before the hall is used for preparation, it shall be fully sanitized to ensure that the hall is free from any other electronic device or components of electronic devices. Every entry to the hall shall be guarded by police force. Every hall shall have a door-frame

metal detector. Every person who enters the hall shall be frisked at every entry. Entry to this hall shall be on production of Identity Card of the authorized officials/passes issued by the District Election Officer (DEO). Nobody will be allowed to carry any electronic device inside the hall including cell phones, camera and spy pens. Similarly, nobody will be allowed to carry anything out of the preparation hall.

### 8.3 Manpower for preparation

Only the authorized engineers of BEL and ECIL shall be associated with the preparation of EVMs. BEL and ECIL shall be fully responsible for integrity, efficiency and competence of their engineers. List of engineers deputed by BEL and ECIL for carrying out task during the preparation of EVMs in a district along with their identity card numbers etc. shall be communicated in writing by BEL and ECIL to the DEO. No engineers, technicians or other technical staff, except authorized engineers/technical staff of BEL and ECIL, shall be allowed to enter the preparation hall. Authorized persons will be allowed to enter the preparation hall only after proper identification using photo identity documents. It may be noted that a separate team will be required for each EVM in which 1000 votes are cast during mock poll because the time required for casting of 1000 votes will be at least 4 hours.

### 8.4 Additional tasks during preparation

Detailed instructions of the tasks to be done during preparation of Balloting Units and Control Units of EVMs have been given the Handbook for Returning Officers. In addition to these tasks, following additional tasks shall be performed: -

#### 8.4.1 Checking of Balloting Units (BUs) –

Outer cover of BUs shall be opened and inside of BU shown to candidates and their representatives at the time of preparation of EVMs. BU shall be examined by BEL and ECIL engineers who will certify as in **Annexure-11** that all components of BUs are original. If any BU is found defective, it will be kept aside and can be taken back to the factory of BEL and ECIL for repairs. No repairs shall be carried out in the field. Changing of components in the field is strictly prohibited. Detailed instructions of checking of BU shall be issued separately by BEL and ECIL for their respective machines.

These instructions will include a list of equipment which the engineers will be required to carry within the preparation hall. Security personnel will not allow any other equipment to be carried into the preparation hall.

#### **8.4.2 Conduct of Mock Poll:**

Casting of votes against all 16 candidate switches, observation of result & clearing of mock poll data will be done for each EVM. In 5 % (five percent) of EVMs at least 1000 votes shall be polled during the mock poll. In rest of the machines number of votes polled during the mock poll should be to the satisfaction of the representatives of candidates. Representatives of candidates shall be allowed to do the mock poll themselves. Signatures of representatives of candidates shall be taken in a register in Annexure-12 as token of having done mock poll themselves. It may be ensured that the pink paper seal of the CU which has been applied on the CU at the time of FLC is not damaged in any manner in this process.

#### **8.4.3 Demonstration of printout of results:**

A printout of the results of mock poll as well as a sequential print out of every vote polled during the mock poll shall be taken out for at least 5% of EVMs and shown to the representatives of candidates. Representatives of candidates shall be allowed to pick machines randomly for this purpose. Signatures of representatives of candidates shall be taken in a register in Annexure-13 as token of having seen the print out and confirmed that there is no discrepancy between the votes polled during the mock poll and results in the print out.

#### **8.4.4 Sealing of plastic cabinet of BU with pink paper seal:**

Detailed instructions of sealing the BU with thread seals are mentioned in the Handbook for Returning Officers. In addition, the BU shall be sealed with a special “pink paper seal” supplied by India Security Press, Nasik, in the presence of candidates or their representatives at the time of preparation of EVMs. Pink paper seal shall be fixed at the lower most portion of the BU in such a manner that no candidate’s button or candidate’s name or symbol is

hidden by the seal. After affixing the pink paper seal, BEL / ECIL engineer shall put his signature on the pink paper seal. Candidates or their representatives shall also be allowed to put their signatures on the pink paper seal with name of the candidate, party before the signature. Candidates and their representatives should also be allowed to note down the serial number of the pink paper seal of the CU. A register in Annexure -14 shall be maintained to note down the serial no. of the pink paper seal used on the Balloting unit by clearly mentioning unique ID of the BU and pink paper seal no. Signatures of candidates and their representatives will also be obtained on this register. Photocopies of this register will be given free of cost to all candidates once preparation is over.

#### **8.4.5 Supervision of the preparation:**

Preparation shall be supervised either personally by the RO or one of the AROs deputed by the RO for this purpose. The process of preparation of EVM should be fully video-graphed.

\*\*\*\*\*

## CHAPTER – 9

### INSTRUCTIONS ON DISPERSAL OF EVMs

- 9.1** When the EVMs are taken out of the strong room for dispatch to polling stations, to polling stations, the usual precaution of informing the date and time of opening of strong room in writing to the candidates/ agents shall be followed.
- 9.2** At the time of dispatch, the Presiding Officers shall be advised to compare the machine number inscribed on the metal label and the adhesive sticker and also verify the PS no indicated on the sticker and compare it with PS no. mentioned in the address tag before accepting the EVM. Discrepancy, if any, shall be brought to the notice of the officer in charge of dispatch arrangement and be reconciled.
- 9.3** The candidates may be advised to share the machine number of the EVM (both CU/ BU) allotted to the specific PS with their polling agent/ agents appointed by them so that they are in a position to inspect the EVM for their satisfaction before the commencement of mock poll at the polling station on the poll day. The Presiding Officers shall be advised to show the machine number to the agents present before the commencement of the mock poll. It is relevant to note that as per the existing instructions the presiding officer is supposed to mention the number of CU used; serial number of CU used; numbers of BU/BUs used and serial numbers of BU/BUs used at the polling station in the Presiding Officer’s Diary. This instruction shall be scrupulously followed.

\*\*\*\*\*

## CHAPTER – 10

### INSTRUCTIONS TO ZONAL/SECTOR/AREA OFFICERS REGARDING EVMs

The following instructions shall be complied with for ensuring safe movement of EVMs by Zonal/Sector/Area Magistrates. Following category of EVMs move on poll day with either poll party or Sector/Zonal/Area Magistrate:-

#### 10.1 Category "A"

Polled EVMs: Those EVMs in which votes polled at polling stations are recorded and which are closed at the end of poll after following due procedure.

#### 10.2 Category "B"

Defective polled EVMs which become defective after some votes are recorded in it.

#### 10.3 Category – "C"

Defective unpolled EVMs which become defective before commencement of poll and are replaced.

#### 10.4 Category – "D"

Unused EVMs: Reserve EVMs which are with Sector/Zonal/Area Magistrate, and are not used in actual poll.

10.5 Zonal Magistrates and Area Officers who are given EVMs from reserve stock will maintain a register where the particulars of Balloting Units (BU) and Control Units (CU) issued to them are mentioned and a receipt shall be obtained for the machines given to them. Such officers should also maintain the accounts of EVMs replaced, if any, in the register maintained by them for this purpose duly signed by the concerned Presiding Officers, indicating time of replacement.

10.6 Zonal/Sector/Area Officers should visit every polling station in their jurisdiction as many times as possible on the poll day and check working of EVMs and other things.

10.7 EVMs of category 'A' are stored in a Strong Room as per procedure laid down.

- 10.8** EVMs of category ‘B’ are also stored separately with the EVMs of category ‘A’ in a Strong Room. In respect of this category of EVMs, the Sector/Zonal/Area Magistrate shall keep a record of it and furnish a certificate to the effect while returning the EVMs of category ‘D’ on the next day of poll. The information furnished by them shall be tallied with Presiding Officer’s diary by the Returning Officer and the Observer before commencement of counting of votes.
- 10.9** EVMs of category ‘C’ are stored separately in a separate room other than the strong room. The sticker of defective un-pollled EVMs should be pasted on the carrying cases of such category of Balloting Units and Control Units, for technical evaluation of the same by the manufacturer.
- 10.10** EVMs of category ‘D’ are also stored separately in a separate room, other than the strong room where polled EVMs are kept, by Sector/Zonal/Area Magistrate. The sticker of unused EVMs should be pasted on the carrying cases of such category of Balloting Units and Control Units.
- 10.11** The store room where the EVMs of category ‘C’ and ‘D’ will be kept is to be decided in advance and intimated to the political parties/candidates. It should not be in the vicinity of the collection and the counting center so as to arouse any suspicion. This category of EVMs should also not be collected on the day of poll, rather it should be collected on the next day of poll from the concerned Zonal/Sector/Area Officers. On the day of poll, these category of EVMs should be in the personal custody of Zonal/Sector/Area Officers, as these are unused EVMs. Also, proper documentation of such and other unused EVMs is to be made before they are transported to the store room by the Zonal/Sector/Area Magistrate themselves

\*\*\*\*\*

## CHAPTER – 11

### VOTING COMPARTMENT TO BE USED IN POLLING STATIONS

In order to maintain secrecy of vote at the time of poll and uniformity on use of voting compartments, the following instructions shall be strictly adhered on use of Voting Compartment at Polling Stations –

- The voting compartments shall be made only of corrugated plastic sheet (flex-board) of steel grey colour, which is opaque and reusable.
- The Voting Compartment shall be in three folds, each fold having dimension of 24”X24”X30” (Length X Width X Height). Increase height of 30” is mandatory.
- All the three sides of the voting compartments shall be printed as mentioned at Annexure-9.
- The height of the table on which the voting compartment is placed should be 30” as shown at **Annexure-9**.
- If more than one BU is used for poll, the width of the voting compartment may be increased 12” for each additional BU. Where additional Balloting Units are being, Presiding Officers shall arrange the Balloting Units in the manner as shown at **Annexure-9**. While placing the EVM in the voting compartment, it must be ensured without fail that secrecy of voting is not violated. For this purpose, it must be ensured that it is not near the window or the door of the polling station.

The interconnecting cable of Balloting Unit/VVPAT should be so routed that it does not obstruct the movement of voters inside the polling station and they have not to tread or trip over it, but **the entire length of the cable should be visible and under no circumstances be concealed under the cloth or under the table.**



## CHAPTER – 12

### INSTRUCTIONS ON USE OF EVMs IN POLLING STATIONS

In order to ensure that the conduct of the Presiding Officer and other polling staff, in no way gives scope for any complaint, the Commission has issued the following instructions for strict adherence: -

- 12.1** The D.E.O shall supply a printed sample of EVM Balloting unit pasted on a cardboard (real size) to all the presiding officers along with other polling materials at the time of dispatch. While printing such model ballot, care shall be taken to ensure that only dummy name and dummy symbols that are not in use, are used and not any real names or symbols. It shall be printed in color so that ‘blue button’ ‘green light’ and ‘red light’ etc. are clearly represented.
- 12.2** Whenever any voter asks for help or expresses inability to vote using EVM, the presiding officer can explain to the voter the voting process using the cardboard model of the EVM ballot in such a manner that the voter is able to understand. This shall be done outside the voting compartment only in the presence of polling agents and never inside the voting compartment.
- 12.3** The Presiding Officer or other polling staff shall not frequent the voting compartment as that may give scope for complaints.
- 12.4** In order to ensure that no voter has committed any mischief by pasting any paper, tapes etc., on the symbol/ names / ballot button, the presiding officer may from time to time make an inspection of Balloting unit (BU)- but he should make it a point to do so in the immediate presence of polling agents when there is no voter inside the voting compartment.
- 12.5** Any complaint about the conduct of the polling staff at the polling station shall be taken seriously and properly enquired. The Observers are being instructed to take serious note of such complaints and conduct or cause enquiry into such allegations and submit reports to the Commission.
- 12.6** All the CUs/BUs allotted to Polling Stations as well as the reserve machines shall be kept in the strong room in the presence of candidates/agents. They can also be allowed to affix their seal on the lock of the strong room.

\*\*\*\*\*

## CHAPTER – 13

### MOCK POLL ON THE DAY OF POLL

#### 13.1 Mock poll before commencement of actual poll

Mock poll shall be conducted normally one hour before the scheduled hour of commencement of poll. All contesting candidates should be informed in writing well in advance that mock poll would start one hour before the commencement of poll and they should be advised to instruct their polling agents to be present in time for the mock poll. Polling agents of at least two candidates should be present at the time of Mock Poll. However, if polling agents of at least two candidates are not present, the Presiding Officer may wait for 15 more minutes before conducting the mock poll and if the agents still do not come, then the Presiding Officer may go ahead and start the mock poll. It is further clarified that after waiting for 15 minutes, there is a possibility that only one Polling agent may be present, in that situation also, the Presiding Officer should go ahead and start mock poll. In such case, there should be specific mention in the mock poll certificate on this aspect.

13.1.1 During the Mock poll, the Balloting Unit (s) should be placed in the Voting Compartment and Control Unit on the table of the Presiding/Polling Officer who will operate the Control Unit. At least two polling officers with the polling agents should be present in the Voting Compartment to watch the polling agents operating on the Balloting Unit, and to keep a record of the votes cast and tally the polled votes.

13.1.2 The mock poll should be conducted with the polling agents voting at random for each of the contesting candidates. A total of at least 50 votes should be polled in the mock poll. In the case of absence of polling agents of any of the candidates, one of the polling officers or other polling agents may record the votes for such candidates. The polling officers present in the Voting Compartment should ensure that votes are recorded for each of the contesting candidates. After recording of the minimum of 50 votes, the Presiding Officer will ascertain the result in the Control Unit in the presence of the Polling agents and confirm that the result is tallying with the votes polled in respect

of each candidate. Thereafter, Presiding Officer will prepare and sign the mock poll certificate in the prescribed format i.e. in Annexure-15.

- 13.1.3 The Presiding Officers shall ensure that the data of the mock poll is deleted, without fail, before the official poll starts. This is very critical step and this should be emphasized during training.
- 13.1.4 The Presiding Officers shall mention the names of the Polling agents and the candidates (and their party affiliations), whom they represent and also obtain their signatures on the completion of mock poll on the certificate.
- 13.1.5 Where a micro-observer has been appointed at any polling stations, he should also participate in all the proceeding of the mock poll and his signature should also be obtained on the mock poll certificate. Further, these proceedings should be videographed wherever videography arrangement has been made at a polling station.
- 13.1.6 The Returning Officer through the Sector Officers and using the communication link with the polling station/ mobile teams, shall track the conduct or otherwise of mock poll, and ascertain the mock poll status. Non-confirmation of mock poll could be indicative of non-commencement of poll and in that case the Returning Officer shall make immediate intervention to sort out the problem.
- 13.1.7 The polling stations not having the presence of agents of the candidates of recognized parties and where the mock poll had to be conducted in the absence of agents or with the polling agent of only one candidate shall merit focused attention of the election machinery. Interventions such as deployment of micro-observers, deployment of video cameras (if not already done), frequent visits by sector officers and other senior officers should be ensured in such cases.

## **13.2 Mock Poll in case of replacement of EVM**

If any defect arises in the Balloting Unit (BU) or Control Unit (CU) of the EVM during poll process, the entire set of EVM (both BU & CU) should be replaced by new set of EVM (BU & CU), a mock poll should be conducted on the new set of EVM (both BU & CU) before it is put to use. However, in this case, it would be \

sufficient to cast at least one vote each for each of the candidates. A new mock poll certificate should be recorded in such a case. A note should also be added in such cases, in the original mock poll certificate, that the original Control Unit was replaced, and that mock poll was conducted on the new Control Unit before putting it to use. The exact time of replacement should also be mentioned in the note.

### **13.3 Recording of Poll Start and Poll End Date and Time**

It has been brought to the notice of the Commission that in the elections where post – 2006 make EVMs were used, in some cases, the date and time of start and end of poll displayed in the Control Unit of EVM during the process of counting of votes did not match with Indian Standard Time of start and end of poll leading to confusion in the minds of stakeholders. This can only happen if the date and time displayed in the Control Unit are not checked at the time of Candidate Set procedure and also at the time of poll. To remove such confusion in future, the Commission has decided to issue the following instruction in this regard:

- 13.3.1 The display of date and time in the Control Unit of the EVM shall be checked each time the power switch of Control Unit is switched on during the process of First Level Checking of EVM and again at the time of Preparation of EVM by Returning Officer. In case any difference from Indian Standard Time is noticed the clock shall be recalibrated by the engineers of the BEL/ECIL.
- 13.3.2 The Presiding Officer, at the end of Mock Poll at the polling station, shall invariably check and note the date and time shown in the display of the Control Unit and also the actual date and time at that point of time as well as any discrepancy between the two, if any, in the Mock Poll certificate Annexure-15 and also in Presiding Officers' Diary.
- 13.3.3 At the time of closure of poll, the presiding officer shall make a note of the Poll end date and time displayed on the CU in the presiding officer's diary.
- 13.3.4 During the process of counting of votes, a copy of the Mock Poll certificate prepared by the Presiding Officer shall be brought to the counting table with the Control Unit pertaining to that polling station.

\*\*\*\*\*

## CHAPTER – 14

### REPLACEMENT OF EVMs DURING POLL

- 14.1** In case of replacement of CU or BU due to reason at any polling station, the sector officer or any authorized officer who effects such replacement shall prepare a special report indicating the machine number of the existing CU/BU and new CU /BU separately. The officer shall also mention in the special report, the reason of such replacement and votes polled in the replaced machine at that point of time of replacement. One copy of the special report should be left with the Presiding Officer while retaining a copy to be handed over to the R.O.
- 14.2** In case replacement of any EVM becomes necessary, the entire set including the CU and all the BUs shall be replaced. Before starting poll in the new EVM, a mock poll will be done according to the instructions for mock poll in para 13.2 and a mock poll certificate will be given by the presiding officer separately for this EVM.
- 14.3** In case of replacement, the Unique ID number of the CU and BUs which have been used after replacement should be marked against the concerned polling station in the EVM tracking software.
- 14.4** Reception of EVMs after Polls -The machines shall be escorted back after the poll is over to the reception centers under proper escort. After all formalities are completed, the EVMs shall be kept in strong room and the room sealed in the presence of the candidates/their agents and Observer.

\*\*\*\*\*

## CHAPTER – 15

### INSTRUCTIONS ON EVM IN CASE OF RE-POLL

- 15.1 In case of re-poll, the EVM required for re-poll shall be drawn from the reserve list and the CU/BU number shall be informed to the candidates/agents in writing. Care shall be taken to ensure that the address tag on the CU and BU clearly mentions it to be the EVM for use in the re-poll indicating the date and PS no.
- 15.2 In case of re-poll, a pre-printed self-adhesive sticker "Re-poll EVM" shall be pasted on the EVM (CU & BU) as well as carrying cases of the EVM to be used for re-poll. After re-poll the strong room shall be re-opened in the presence of the candidates/their agents and observer for the storage of the re-poll EVM. This re-poll EVM should be placed together with the old EVM which was used earlier in the original poll. At the time of placing the 'Re-poll EVM' after repoll in the strong room, another pre-printed sticker with bold print **"TO BE COUNTED"** shall be pasted on the re-poll EVM. Another pre-printed sticker **"NOT TO BE COUNTED"** shall be put prominently on the old EVM, to remove any confusion at the time of counting.
- 15.3 In case of re-poll, the unique ID number of the CU and BUs used in re-poll should be entered in the EVM tracking software.

\*\*\*\*\*

## CHAPTER – 16

### SECURITY MEASURES FOR POLLED EVM STORED FOR COUNTING OF VOTES

The following instructions shall be strictly followed for the security and safety of strong rooms where the polled EVMs are kept for counting of votes: –

- i The strong rooms should have double lock system. One key should be kept with District Election Officer and the other with Returning Officer of concerned assembly constituency.
- ii Two cordoned security arrangements should be made round the clock for the strong rooms having polled EVMs kept for counting of votes. The CPF should man the innermost perimeter security immediately outside the strong room and the State Armed Police should man the outermost perimeter security.
- iii All contesting candidates should be intimated in writing to depute their representatives to keep a close watch on security arrangement of strong room. They should be allowed to stay outside the inner perimeter at a location, which enables them to view the entry points of the strong room. As far as possible, facilities such as proper shade, drinking water, etc. shall be provided to them. CCTV shall be arranged at the location, so that they can see the strong room door on CCTV. The CCTV display of Strong Room shall be arranged on a large TV screen at the place earmarked for the representatives of Political Parties and agents of the candidates, so that they can continuously monitor the Strong Room.
- iv There should be sufficient arrangement of fire extinguishers near and inside the strong room.
- v There should be an arrangement round the clock for the security of unused EVMs also.
- vi No one should be allowed to enter the inner perimeter without following the protocol, as under:-
  - a) The log book shall be maintained by the CPF in which entry should be made about date, time, duration, purpose and name(s) of any one crossing the

second security ring i.e. the middle perimeter. This includes visits by the Observers or DEOs or SPs or candidates or their agents or any other person.

- b) Video cameras should be provided to the CPF contingent to record all visits made by such visitors.
- vii It should be ensured that there is uninterrupted power supply at the strong room locations during the entire period wherein EVMs are stored. CEO may address the Chairman of Electricity Board concerned separately regarding this. Local Electricity Board officials should also be asked to ensure the same. Contingency arrangement of stand-by generators should be made to ensure uninterrupted power supply.
- viii All the entry points (doors etc.) of strong rooms should be under constant videography using the web-cams and laptops available. If there are other doors of the strong room, they should also be covered by the web-cams/videography.
- ix Returning Officers should visit the storage campus (upto the inner perimeter only) every day in the morning and evening and check the log book and videography and send a report to the DEO on the status every day.
- x No vehicle, including that of any official or ministers or any other political functionary, should be allowed inside the secured campus where the EVMs are stored. Alighting point for the vehicles should be marked clearly ahead of the outer security perimeter itself; beyond it should be a pedestrian zone only.
- xi DCs and SPs shall be personally responsible for security of strong room within the district and meticulous implementation of the protocol.

The copy of this Manual should be made available to all political parties, candidates, DEOs, ROs and CPF commandant.

\*\*\*\*\*



## CHAPTER – 17

### INSTRUCTIONS RELATING TO COUNTING

#### 17.1 General Instructions

- 17.1.1 At the time of counting, only the CUs are normally needed. BUs need not be taken to the Counting Hall. Before starting the counting in the CU, the unique ID number of the CU, the Unique ID number of the Pink Paper Seal and the unique ID number of Green paper seal should be verified from the record and shown to the polling agents.
- 17.1.2 In Post-2006 EVMs, the Poll start date and time and poll end date and time displayed on the CU should be verified from the record and shown to the polling agents.
- 17.1.3 During counting, a close up video recording of the display on the CU should be done at all times, so that every thing displayed on the CU, including the votes recorded in favour of each candidate in the CU, are recorded on the video.

#### 17.2 Procedure in case of discrepancy in the date and time of start and end of poll

- 17.2.1 In case of any discrepancy in the date and time of start and end of poll displayed in the Control Unit with Indian Standard Time of start and end of poll, the difference will be compared with the date and time noted by Presiding Officer in the mock poll certificate.
- 17.2.2 If the date and time difference at the time of mock poll does not match with the date and time difference of start and end of poll at the time of counting, the EVM will be kept aside and the matter will be referred to the Commission for its decision. If on other hand, the difference of date and time at the time of mock poll matches with the difference of date and time of start and end of poll noticed at the time of counting, the discrepancy will be explained to the candidates and their representatives and the votes polled in the EVM will be counted in the usual manner.

### 17.3 Procedure in case the close button not pressed at the end of the poll –

The following action be taken during counting of votes, in such circumstances, in the presence of candidates/their authorized agents, under videography: -

- 17.3.1 In case any Control Unit does not display result due to not-pressing of "Close" button by the Presiding Officer in the polling station at the close of poll, it should be kept back inside its carrying case and then be kept in the Returning Officer's custody in the counting hall. Counting of votes in other machines should continue as usual.
- 17.3.2 When counting of votes in other machines is completed, the Returning Officer and Observer should see whether the margin of votes between the first candidate and the runner up is more or less than the votes polled in such machine(s).
- 17.3.3 In both the cases where the margin of votes is more or less than the total votes polled in that machine(s), the Returning Officer/Counting Supervisor shall press the "Total" button of the Control Unit to see the total votes polled in that machine(s). In case, total votes polled in the machine(s) tallies with the total votes polled mentioned in the Form-17 C, the Returning Officer/Counting Supervisor shall press the "Close" button of the Control Unit(s) so that "Result" button can be pressed for getting result data explaining the entire issue to the candidates and/or their authorised agents and recording a proceeding in this behalf with the signatures of the candidates/their authorised agents. In such a case, the Returning Officer and Observer should send a detailed report to the Commission in the format mentioned at Annexure-16.
- 17.3.4 In case, total votes polled in the machine(s) does not tally with the total votes polled mentioned in the Form-17 C, the matter should be referred by the Returning Officer to the Commission for its decision and action may be taken as per the direction of the Commission. In such a case, the Returning Officer and Observer should also send a detailed report to the Commission in the format mentioned at Annexure-17, where the margin of votes between the candidates having highest vote and the runner up is more than the votes polled in the Control Unit in question, and in Annexure-18, where such margin is less.

## 17.4 Instructions in case of EVMs malfunctioning at the time of Counting –

The following action to be taken in case of malfunctioning of EVM during counting of votes during elections: -

- 17.4.1 In case any Control Unit does not display result, it should be kept back inside its carrying case and then be kept in the Returning Officer's custody in the counting hall. Counting of votes in other machines should continue as usual.
- 17.4.2 When counting of votes in other machines is completed, the Returning Officer and Observer should see whether the margin of votes between the first candidate and the runner up is more or less than the votes polled in the malfunctioned machine (s).
- 17.4.3 In both the cases where the margin of votes is more or less than the total votes polled in the malfunctioning machine (s), the Returning Officer should try to retrieve the result from this machine, with the help of engineers of BEL/ECIL, using Auxiliary Display Unit (ADU) in the presence of candidates or their election agents. If the result can be retrieved by using an ADU, the result of the election can be declared accordingly. In such a case, the Returning Officer and Observer should send a detailed report to the Commission in the format mentioned at Annexure-19.
- 17.4.4 In case it is not possible to retrieve the result from the malfunctioning machine even by using ADU, then the Returning Officer should try to retrieve the result from the machine by taking a print out of the result with the help of engineers of BEL/ECIL. If the result can be retrieved by using a printer, the result of the election can be declared accordingly. In such a case also, the Returning Officer and Observer should also send a detailed report to the Commission in the format mentioned at Annexure-19.
- 17.4.5 If the result from the malfunctioned machine can not be retrieved even by using printer, the matter should be referred by the Returning Officer to the Commission for its decision and action may be taken as per the direction of the Commission. In such a case, the Returning Officer and Observer

should also send a detailed report to the Commission in the format mentioned at Annexure-20, where the margin of votes between the candidates having highest vote and the runner up is more than the votes polled in the malfunctioned EVM, and in Annexure-21, where such margin is less. In no case the machine should be opened, or its outer or inner seals disturbed in any manner. There should be no attempt to repair the machine. Replacement of any parts of the EVM in the field level is strictly forbidden.

17.4.6 In case, it is not possible to retrieve the result from the CU even after using printer, as instructed in para 17.4.4, the printed paper slips, where VVPAT is used, of the respective VVPAT to be counted as per procedure below: -

- a) The VVPAT unit(s) of the respective polling station(s) should be brought to the Counting Table(s).
- b) The address tag(s) of the drop box, after being crosschecked to ascertain the particulars of the polling station, should be removed along with ballot paper slips from the drop box. The counting agents should ensure that no ballot slip is left in the drop box.
- c) If VVPAT unit was replaced during poll, all the VVPAT units used at that polling station should be brought to the counting table and printed paper slips taken out from all such units before beginning the counting of printed paper slips for that polling station.
- d) If any uncut, fully or partially, printed ballot slip has remained connected to the paper roll and has not dropped in the drop box, the slip should not be torn or counted since it is not recorded in the CU if the paper ballot slip is not cut.
- e) The drop box will also have slips of self-test report which should be kept with printed ballot slips as part of record. Such slip can be easily identified as it does not have Sl. No., name or the symbol of any candidate and is larger in length than ballot slips.
- f) The ballot slips so taken out from the drop box(es) should be scrutinized, one-by-one, to ascertain the names of the candidates in

whose favour the same have been cast. On such scrutiny, each ballot slip should be placed in the respective compartment of the candidate concerned on the counting tray to be provided for the purpose.

- g) After all the ballot slips have been so scrutinized and sorted out candidate-wise, the number of ballot slips cast in favour of each candidate shall be counted and made into bundles of 25 each.
- h) The number of ballot slips so counted in respect of each candidate should be totaled up to tally with the total number of votes cast at the polling station as shown in item-6 of Part-1 of Form-17C pertaining to that polling station.
- i) The total number of ballot slips, so counted and tallied, and the number of ballot slips cast in favour of each individual candidate should then be announced aloud to the hearing of all candidates, their agents and others present in counting hall.
- j) The result of counting, candidate-wise, so ascertained and announced should then be recorded in Part-II of Form-17C.
- k) In case the total number of ballot slips taken out from the drop box does not tally with the number of votes recorded in the EVM as per item-6 of Part-1 of Form-17C, the result of such counting of ballot slips should not be taken into account for the purpose of incorporation in Form-20 and the matter reported to the Commission for its further directions in the matter.

A report regarding counting of printed ballot slips of VVPAT is to be sent to the Commission in the following format through Chief Electoral Officer concerned for information.

S. No.	No. & Name of Assembly Constituency	Polling Station No.	Unit ID of Control Unit from which result could not be retrieved	Unit ID of VVPAT	Total No. of votes recorded in EVM as per Item 6 in Part-I of Form-17C	Total No. of printed ballot slips taken out of the drop box(es)
1.	2.	3.	4.	5.	6.	7.

## 17.5 Sealing of EVMs after counting of votes

After completion of counting, all such Control Units whether result has been retrieved from it or not, the Control Unit should be kept back inside its carrying case. The carrying cases should then be sealed once again. The Returning Officer and Observer should put their signatures on the seal. All candidates and their election agents should also be allowed to put their signature on the seal. The Control Unit should be then kept in the strong room(s).

\*\*\*\*\*

## CHAPTER – 18

### DISPOSAL OF EVMs

1. In 2007, the manufacturers of EVMs opined that the life of EVMs is about 15 years and that it is risky to use machines older than 15 years in future elections. Thus the manufacturers have recommended disposal of the entire 1989-90 batch of EVMs.
2. The Commission constituted a Technical Expert Committee comprising Prof. P.V. Indiresan, Prof. D.T. Shahani & Prof. A K Agarwala to give its opinion on whether EVMs of 1989-90 batch have become unusable.
3. Technical Expert Committee recommended the methodology for weeding out 1989-90 EVMs for disposal.
4. Approval of Government of India is required for destruction of EVMs.
5. Following guidelines for destruction of EVMs shall be followed:
  - a) PCBs shall be separated from Plastic Housings;
  - b) All components mounted on PCBs of CU, BU & Display shall be removed/ chopped off and crushed;
  - c) The bare PCBs shall be cut into minimum 4 pieces and crushed;
  - d) The remaining plastic assemblies/housing shall also be cut into 4 to 6 pieces and crushed;
  - e) Plastic waste shall be recycled to ensure that environment is protected;
  - f) Entire process of the disposal/destruction of EVMs should be videographed;
  - g) A copy of the video of disposal/destruction of EVMs should be sent to the CEO concerned and ECI;
  - h) The video of disposal/destruction process shall be viewed at CEO concerned /ECI to certify that nothing adverse was noticed;

- i) The guidelines/safeguards for destruction of electronic items, issued by the Pollution Control Board/Ministry of Environment and Forests etc. or any other law for the time being in force, shall be followed;
- j) It shall be ensured that e-wastes are channelized to registered dismantler or recycler;
- k) A proper record of each BU and CU destroyed/destroyed should be maintained in a register –
  - i) Serial number/ID of each BU and CU destroyed, date-wise, shall be entered in a register (separate registers for BU & CU should be maintained);
  - ii) On the close of the day a certificate should be recorded after the last entry to the effect that **“today on.....(date) ... number of BU/CU (as the case may be) has been destroyed in my presence”** and shall be signed by the officer of the manufacturer nominated for the purpose and signatures of the representative of the CEO concerned and e-waste agency shall also be obtained.

\*\*\*\*\*



## CHAPTER – 19

### TECHNICAL EXPERT COMMITTEE ON EVMs & VVPATs

#### 1. Composition of First Technical Expert Committee on EVMs

- ❖ Central Government appointed the Electoral Reforms Committee in January, 1990 (Goswami Committee) consisting of representative of several recognized National and State Parties.
- ❖ The Electoral Reforms Committee felt that the machines should be tested by technical experts with a view to removing any doubts or misapprehensions in the minds of the public with regard to credibility of the working of the machines and desired that a clearance from the technical experts to the effect that doubts and misapprehension entertained about the credibility of the machines were not well founded should be obtained.
- ❖ An Expert Committee for the evaluation of the electronic voting machines was constituted under the chairmanship of Professor S. Sampath, Chairman Technical Advisory Committee, Defence Research & Development Organization, Ministry of Defence, Professor PV Indiresan of the IIT Delhi and Dr. Rao C. Kasarabada, Director, Electronic Research & Development Centre, Trivandrum.
- ❖ The Committee, after a review of the material presented to it, technical presentation by the manufacturers, meeting election administrators and technical experts and also detailed laboratory tests, came to the conclusion that the electronic voting machine is a secure system. The expert committee, therefore, unanimously recommended, in April, 1990, the use of the electronic voting machines without further loss of time.

#### 2. Composition of Second Technical Expert Committee

- ❖ The Commission constituted the Second Technical Expert Committee in December, 2005 comprising Prof. P.V. Indiresan, Prof. D.T. Shahani of IIT Delhi and Prof. A.K. Agarwala of IIT Delhi to get the upgraded EVMs (Post 2006 EVMs) evaluated before finally accepting these machines for actual use in elections.

- ❖ Subsequently, the Commission has been consulting the group of technical experts comprising Prof. (Late) P.V. Indiresan (member of the earlier committee), Prof. D.T. Shahani and Prof. A.K. Agarwala of IIT Delhi, on all EVM related technical issues.

### **3. Expansion of Technical Expert Committee**

In November, 2010, the Commission expanded its Technical Expert Committee by including two more experts, namely, Prof D.K. Sharma from Department of Electrical Engineering, IIT of Mumbai and Prof. Rajat Moona from Department of Computer Science and Engineering, IIT of Kanpur (now Director General, C-DAC).

### **4. Functions of Technical Expert Committee on EVMs/VVPATs**

The Technical Expert Committee on EVMs/VVPATs provides the following assistance to the Commission:-

- (i) Opinion on technical issues of EVMs & VVPATs;
- (ii) Development and designing of EVMs & VVPATs;
- (iii) Evaluation of EVMs & VVPATs.

\*\*\*\*\*

## CHAPTER – 20

### EVM TRACKING SOFTWARE (ETS)

EVM Tracking entry application is developed for creating a centralized database of all 36 States and UTs of India. It allows Tracking of Control Units, Balloting Units and VVPATs with their locations. This application has the facility to create and enter the warehouse details in which the stock entry of CUs, BUs and VVPATs could be done by Warehouse In-charge. Transfer of CUs, BUs and VVPATs once entered will not require re-entry of data. It also keeps the check of duplicate entry of CUs, BUs and VVPATs in all the warehouses across the country.

This Application has to be used at CEO/DEO/Warehouse In-charge / ECI Admin levels.

Data Entry of CU/BU/VVPAT is to be made in specific warehouses. The Warehouse is created by the DEO providing all the relevant details. Once the Warehouse is created, the DEO creates the login id of the warehouse in-charge. Data Entry of CU/BU/VVPAT is done in the Master Stock Register which is accessible to both the DEO and the warehouse in-charge. The data entry of CU/BU/VVPAT can be done only at the Warehouse In-charge level.

Details of all EVMs in the district must be entered in Master Stock Register (MSR). MSR must be maintained warehouse-wise for every district in the format provided in the MSR Screen. Every CU, BU and VVPAT in the district whether in working condition or not must be entered in the MSR.

Transfer of CU, BU and VVPAT at the State level, District level and the warehouse level can be initiated by the authorized personnel. Supply orders are generated for each transfer; the source and destination entities can access the order and proceed with the operation. All the officials assisting in this purpose must adhere to the process to accomplish successful transfer of both CU, BU and VVPAT.

For the purpose of elections, the CU, BU and VVPAT sent to the polling stations are randomized at two different levels – DEO level STRONG ROOM and Warehouse In-charge (STRONG ROOM AC) level. The CUs/Bus/VVPATs which are working and successfully pass both the first level and second level randomization will be sent to the polling stations.

For physical verification of CU/BU/VVPAT unit in warehouse with the digital data entry in stock of warehouse in ETS, the Commission generates physical verification cycle in ETS from time to time. Warehouse stocks are updated accordingly by warehouse in-charge.

Various MIS (Management Information Service) reports are made available in the ETS for its users at the level of ECI Admin/CEO/DEO/WI/Manufacturer to check the status of work allocated and to identify pending issues.

For detailed application kindly see User Manual for ETS available at ETS login page

## 20.1 Mobile Applications

Android based Mobile Application interfaced with the ETS, developed for Stock-Taking of EVMs & VVPATs, is equipped with the facility of bar code reader & camera, to ensure error free recording of EVM & VVPAT data at the time of Stock-taking of EVMs.

This Mobile Application can work in offline mode also for capturing the data of EVMs & VVPAT for uploading the same into the EVM Tracking Software. However, it needs net- connectivity (Wi-Fi or data connection) to login and to upload the captured data.

Users can download and install the mobile app available on Download Manager page of the Election Commission of India's web-site (URL : <http://eciOfficers.nic.in>). This app use Google services, therefore, users are required to update google services, if not already updated, in the mobile phone to be used.

### Detailed Procedure for Stock-taking of EVMs & VVPATs

- ❖ To login, enter warehouse ID in User Name and in the Password field enter your warehouse password thereafter press LOGIN tab.
- ❖ On pressing LOGIN tab, ETS will send One Time Password (OTP). Wait for OTP message. After receiving OTP press Validate OTP tab.
- ❖ After user validation, menu screen will appear.
- ❖ Select Batch Mode [In batch mode you have to select Name of Manufacturer

(BEL/ECIL), Type of Unit (BU/CU/VVPAT) and Owner (ECI/SEC) only one time] and press Next tab.

- ❖ Thereafter, start capturing of data (i.e. Scan Bar Code, Type year of manufacturing, Box Number, Status of Unit and take photograph of Unique ID engraved on the metallic plate).
  - a) In case Bar Code is not available on the unit or is torn/mutilated and not readable by the Bar Code Reader, the Bar Code of the unit is to be printed using the facility in ETS and pasted on the unit for data captured.
  - b) The Sl.No. of the unit can be read from the Sl.No. of plate pasted on the on the unit in case of BU & CU and by powering On the CU and reading the display.
  - c) For manufacturing year, you have to write manufacturing year, which is mentioned on the metallic plate. If manufacturing year is in the form of financial year, say like 2006-07, you should enter 2006.
  - d) In Box Number field, Serial Number of Bulk Carrying Case in which BUs/CUs are kept has to be entered. For convenience and better management fresh numbering of Bulk Carrying cases can be done at the time of Stock taking activity.
  - e) For Status select one of the two options, available in drop down list.
  - f) Readable and clear image of Unique ID of Unit printed on the metallic plate has to be captured.
    - (i) In case of Control Unit, if metallic plate is missing or not readable, install a power pack and switch ON the unit and take photograph of Unique ID displayed on the Display Panel of the Control Unit.
    - (ii) In case of Balloting Unit, if metallic plate is missing or not readable, photograph of Bar Code pasted on the Balloting Unit may be taken.

- ❖ After completion of the above process, press Submit tab. On pressing Submit tab data will be saved in the app and screen is ready for capturing data of next unit.
- ❖ In case Wi-Fi/data connection is available, upload the saved data periodically by pressing Upload tab available in Pending Upload.
- ❖ After uploading pending data, check whether any potential conflict has arisen by pressing Potential Conflict tab. If you find any data in Potential Conflict, it means server already has a unit (BU/CU) of same Unique ID. In such case recheck the data and if you are satisfied that you have entered the correct data and unit is available with you, press Raise Conflict tab, Otherwise make necessary correction and Submit again.
- ❖ If conflict has been raised, you may check the same under Conflict tab, where image uploaded by you and other warehouse is available to verify the correctness. If you find that error is at your end, withdraw the conflict by pressing Withdraw tab and data entered by you will be deleted.
- ❖ It shall be ensured that 100% captured data is uploaded in the ETS.

\*\*\*\*\*

## CHAPTER – 21

### EVM BROCHURE FOR CANDIDATES

Electronic Voting Machines are being continuously used by Election Commission of India in all the General Elections to State Legislative Assemblies & Bye-elections to Assembly/ Parliamentary Constituencies since 2000, and Parliamentary Elections in 2004, 2009 and 2014 were conducted fully on EVMs. This brochure is intended to familiarize political parties, candidates and all other stakeholders with design and functioning of EVMs and also with the administrative security measures put in place by the Commission. This brochure also outlines the rights and duties of candidates and their representatives with respect to use of EVMs.

- **Design of EVM**

EVMs consist of a Control Unit (CU) and Balloting Unit (BU) and the connecting cable. CU is kept with the Presiding Officer. BU is kept in voting compartment. The CU and BU are connected by long connecting cable. The ballot paper to be used in the election is fixed on the BU. [It may also consist of a printer for voter verifiable paper audit trail (VVPAT) as explained in Chapter 22.]

- **Process of voting using EVM**

After identification of voter and after application of indelible ink, the voter is sent to the voting compartment where BU is kept. The Presiding Officer then enables the BU to record vote by pressing Ballot key on the CU. The voter then records his vote by pressing on the BU the button of the candidate of his choice. Once the vote has been recorded, a red LED glows against the name of the candidate for whom vote has been cast and a loud beep sound heard. BU then becomes inactive till it is enabled once again by the Presiding Officer for the next voting. The voter, therefore, cannot cast more than one vote.

- **Technical security features in EVM**

EVM is highly secured machine for the following reasons:-

- (a) The microcontroller chip used in the EVM is one time programmable/ masked chip.

- (b) Software code in the chip can neither be read nor over-written.
  - (c) Software is developed independently in-house by BEL and ECIL.
  - (d) EVMs are stand alone machines which are not accessible remotely from any network.
  - (e) No operating system is used in these machines.
- **Administrative measures and role of candidates and their agents**

Commission has put in place elaborate administrative security measures for EVMs. Political Parties, candidates and their agents play an important role in these measures which are fully transparent. These are described below:-

**(a) Complete physical security**

EVMs are kept in warehouses with special security. These warehouses have only one door and no other entry including window or ventilators. The door has double lock system. One key of the double lock is kept with the warehouse in-charge and the other key is kept with an officer not below the rank of Tehsildar. Warehouse can be opened only after informing political parties in writing at least 24 hours in advance. Warehouse is kept under 24X7 police guards.

**(b) First Level Check (FLC)**

Each EVM is checked by engineers of manufacturers before every election in the presence of representatives of Political Parties. This process is called FLC of EVMs. During FLC, engineers of BEL or ECIL clean the machine and perform full functionality check on it. They also certify that all components of EVMs are original. After checking of the EVMs, a specially designed pink paper seal with a unique serial number is put all around the CU in such a manner that the unit cannot be opened without breaking the seal. Signatures of political parties' representatives are obtained on the pink paper seal. Mock poll by casting 1000 votes is performed on 5% EVMs picked up randomly by representatives of political parties. Result of the mock poll and a sequential print out of all votes polled is shown to the representatives of political parties.



This pink paper seal is manufactured by Security Press Nasik which is uniquely numbered. The entire process is videographed.

**(c) Candidate Set**

After the finalization of the ballot paper, candidate-set operation, according to the number of candidates in the constituency, is performed on the EVMs in the presence of candidates and their representatives. During the process, the ballot paper is affixed on the BU and the EVM is set for a total number of candidates contesting that election plus one additional panel for NOTA. At this time, once again mock poll by casting 1000 votes is conducted on 5% EVMs picked up randomly by candidates and their representatives. Mock poll result and the sequential print out of votes cast is shown to candidates/their representatives. A pink paper seal which is uniquely numbered and manufactured by Security Press Nasik is then put on the BU in such a manner that the unit cannot be opened without breaking the seal. Signatures of candidates and their representatives are obtained on the pink paper seal. The whole process is videographed.

**(d) Mock poll on the poll day**

Before starting the process of actual poll at the polling station, further mock poll is conducted on the EVM in every polling station by casting at least 50 votes. This is done in the presence of polling agents of candidates. The result of the mock poll is shown to the polling agents. The CU is sealed by affixing paper seals and thread seals after clearing the mock poll. All candidates/their polling agents are allowed to put their signatures on such seals. Actual poll is started only after the process is completed and mock poll certificate is issued by the Presiding Officers. In case EVM is replaced for some reason during the poll, mock poll is done in new EVM as well.

**(e) Closing of the Poll**

After the last voter has cast his vote, poll is closed in the EVM by pressing the ‘CLOSE’ button on the CU. No vote can be cast in the EVM after poll is closed in this manner. CU and BU are then put in their respective carrying

cases and the cases are sealed using thread seals. The candidates/polling agents present are permitted to put their signatures on such seals.

**(f) Transportation and storage of polled EVMs**

Polled EVMs are transported from the polling stations to the Receiving Centre under police guards. Candidates and their agents are allowed to follow the EVMs. Polled EVMs are then kept in strong room specially made for this purpose. Strong room is sealed after keeping all EVMs in it. Candidates and political parties are allowed to put their own seals on the lock. The strong room is guarded 24X7 by armed police and is also kept under 24X7 CCTV coverage. Political parties, candidates and their agents are allowed to keep a round the clock watch on the strong room. DEOs are required to provide adequate facilities to political parties and their representatives for this purpose. Strong Room once sealed is opened only on the day of counting, in the presence of candidates and their representatives.

**(g) Various seals to be put on the EVMs**

1. At the time of FLC- Pink paper seal on CU.
2. At the time of Candidate Set-
  - i. Thread seal for the 'Candidate Set' and power pack (Battery) section of CU after setting of number of contesting candidates and installation of battery.
  - ii. Thread seal for Ballot paper screen of BU after fixing ballot paper.
  - iii. Thereafter, two thread seals with address tags of BU.
  - iv. Pink paper seal on BU.
3. After mock poll in polling station-
  - i. Green paper seal signed by polling agents and Presiding Officer for result section of Control Unit.
  - ii. Thread seal with Special Tag for inner door of Result Section.

- iii. Outer Paper Strip Seal covering Result Section and Lower portion of Control Unit.
- iv. Thread seal with Address tag for bottom compartment.

**(h) Counting of Votes:-**

On the counting day, CUs are brought to the counting table and result ascertained by pressing ‘RESULT’ button on Control Unit, one by one, after verification of the intactness of the seals and the unique numbers of the seals. The result is seen on the display panel of the CU by pressing the result button. This is shown to the counting agents of the candidates to their satisfaction. EVM wise result is then recorded by the Counting Supervisor in Part II of Form 17C which is then sent to the Returning Officer for compilation of the round-wise result.

**(i) Randomization of EVMs**

EVMs are randomized twice using computer software. First randomization is done after FLC to allocate EVMs available in the district randomly to assembly constituency. Second randomization is done just before ‘candidate setting’ to allocate EVMs available in an assembly constituency to specific polling stations.

**(j) Miscellaneous transparency measures**

- i. All procedures on EVMs including, randomization, candidate set, mock poll, sealing, transportation, storage and counting are done in the presence of political parties, candidates and their representatives.
- ii. List of EVMs allocated to assembly constituency after first randomization and list of EVMs allocated to polling stations after second randomization, and also the list of reserve EVMs are given to candidates.
- iii. Signatures of political parties’ representative are obtained on pink paper seal of the CU. Signatures of candidates or their representative are obtained on pink paper seal of the BU.

- iv. The unique numbers of pink paper seals of BU and CU are given to the candidates and their representative for comparison at the time of counting.
- v. Signatures of polling agents are obtained on green paper seal and outer paper strip seals used in CUs. Their numbers are also given to polling agents and can be compared at the time of counting.
- vi. Political parties' representatives, candidates and their representatives are allowed to cast votes during mock poll. The mock poll result including sequential print out is shown to them (except of the mock poll at the polling station).

**(k) Action in the case of malfunctioning of EVMs**

In case of malfunctioning, at the time of poll, the EVM is replaced from reserve EVMs. Both BU and CU are replaced and mock poll is conducted on the new EVM before starting the poll on it. The ID number of the new EVM is also communicated to the candidates and their representatives. Votes polled in the EVMs used before replacement can be counted. Both EVMs are, therefore, brought to the counting table on the counting day and result is obtained from both of them. In case of malfunctioning at the time of counting, if result cannot be seen on the display of the CU, the result can be ascertained either by using the Auxiliary Display Unit (ADU) or printed out using the printer.

\*\*\*\*\*

## CHAPTER – 22

### VOTER VERIFIABLE PAPER AUDIT TRAIL (VVPAT)

#### 22.1 Introduction:

In a meeting of all political parties held on 4th October, 2010, the parties expressed satisfaction with the EVM but some parties requested the Commission to consider introducing Voter Verifiable Paper Audit Trail for further transparency and verifiability in poll process. The Commission referred the matter to its Technical Expert Committee on EVMs for examining and making a recommendation in this regard. The Expert Committee had several rounds of meetings with the manufacturers of EVM, namely, BEL & ECIL, on this issue and then had met the political parties and other civil society members to explore the design requirement of the VVPAT system with the EVM.

On the direction of the Expert Committee, the BEL and ECIL made a prototype and demonstrated before the Committee and the Commission in 2011. On the recommendation of the Expert Committee on EVM & VVPAT system, the Commission conducted simulated election for the field trial of VVPAT system in Ladakh (Jammu & Kashmir), Thiruvananthapuram (Kerala), Cherrapunjee (Meghalaya), East Delhi District (NCT of Delhi) and Jaisalmer (Rajasthan) in July 2011. All stake holders including senior leaders of political parties and civil society members participated and witnessed enthusiastically in the field trial. After 1st field trial of the VVPAT system, Commission made a detailed reassessment of the VVPAT system to further fine tune the VVPAT system. Accordingly, the manufacturers developed 2nd version of VVPAT prototype. The same was again subjected to 2nd field trial in the said five locations in July-August 2012.

In the meeting of the Technical Expert Committee held on 19.02.2013, the Committee approved the design of VVPAT and also recommended the Commission to take action on amendment of the rules for using VVPAT. The Government of India notified the amended Conduct of Elections Rules, 1961 on 14th August, 2013, enabling the Commission to use VVPAT with EVMs. The Commission used VVPAT with EVMs first time in bye-election from 51-Noksen (ST) Assembly Constituency

of Nagaland. Thereafter, VVPATs have been used in selected constituencies in every election to Legislative Assemblies and 8 Parliamentary Constituencies in General Election to the House of the People-2014.

## 22.2 Facts on VVPAT:



**Control Unit**

**VSDU**

**Printer (VVPAT)**

**Balloting Unit**

Voter Verifiable Paper Audit Trail is an independent system attached with the Electronic Voting Machines that allows the voters to verify that their votes are cast as intended. When a vote is cast, a slip is printed on the VVPAT printer containing the serial number, name and symbol of the candidate and remains exposed through a transparent window for 7 seconds. Thereafter, this printed slip automatically gets cut and falls in sealed drop box of the VVPAT.

VVPAT consists of a Printer and a VVPAT Status Display Unit (VSDU). VVPAT runs on a power pack (Battery) of 15 volts. Control Unit and VSDU are kept with the Presiding Officer/Polling Officer and Balloting Unit and Printer are kept in the voting compartment.

## 22.3 Legal Provision [The Conduct of Elections (Amendment) Rules, 2013]

The following amendments were made in rules 49A, 49B, 49E, 49M, 49MA, 49T, 56C, 56D, 57C, 92 and 94 of the Conduct of Elections Rules, 1961, in August, 2013, i.e. the amendments now read as under:

**Rule 49A** *“Every electronic voting machine (hereinafter referred to as the voting machine) shall have a control unit and a balloting unit and shall be of such designs as may be approved by the Election Commission: Provided that a printer with a drop box of such design as may be approved by the Election Commission may also be attached to a voting machine for printing a paper trail of the vote, in such constituency or constituencies or parts thereof as the Election Commission may direct”.*

Rule 49B[4(c)] **“where the printer for paper trail is used under the proviso to rule 49A, set the printer as per the number of contesting candidates set in the Control Unit by –**

- i) loading in the printer the serial numbers and names of candidates and symbols allotted to them as given on the balloting units under clause (a);*
- ii) loading paper in the printer; and*
- iii) sealing the printer in such manner as may be directed by the Election Commission”.*

**Rule 49E: –**

- (1) The Control Unit, the Balloting Unit of every voting machine used at a polling station, and the printer for paper trail where used, shall bear a label marked with—
  - (a) the serial number, if any, and the name of the constituency;
  - (b) the serial number and name of the polling station or stations as the case may be;
  - (c) the serial number of the unit of voting machine; and
  - (d) the date of poll.
- (2) Immediately before the commencement of the poll, the presiding officer shall demonstrate to the polling agents and other persons present that no vote has been already recorded in the voting machine, **and where the printer for paper trail is used that the drop box of the printer is empty.**

\*

\*

\*

\*

\*

- (7) Where the printer for paper trail is used, the printer shall also be kept along with the balloting unit in the voting compartment and shall be connected to the EVM in the manner as directed by the Election Commission.

49M – Proviso to sub-rule (3) of the Rule 49M:

**“ Provided that where printer for paper trail is used, upon casting the vote by pressing the button under clause (b), the elector shall be able to view through the transparent window of the printer, kept alongwith the balloting unit inside the voting compartment, the printed paper slip showing the serial no, name and the symbol of the candidate for whom he has cast his vote before such paper slip gets cut and drops in the drop box of the printer”.**

**49MA Procedure in case of complaint about particulars printed on paper slip-**

- (1) Where printer for paper trail is used, if an elector after having recorded his vote under rule 49M alleges that the paper slip generated by the printer has shown the name or symbol of a candidate other than the one he voted for, the presiding officer shall obtain a written declaration from the elector as to the allegation, after warning the elector about the consequence of making a false declaration.
- (2) If the elector gives the written declaration referred to in sub-rule (1), the presiding officer shall make a second entry related to that elector in Form 17A, and permit the elector to record a test vote in the voting machine in his presence and in the presence of the candidates or polling agents who may be present in the polling station, and observe the paper slip generated by the printer.
- (3) If the allegation is found true, the presiding officer shall report the facts immediately to the returning officer, stop further recording of votes in that voting machine and act as per the direction that may be given by the Returning Officer.
- (4) If, however, the allegation is found to be false and the paper slip so generated



under sub-rule (1) matches with the test vote recorded by the elector under sub-rule (2), then, the presiding officer shall-

- (i) make a remark to that effect against the second entry relating to that elector in Form 17A mentioning the serial number and name of the candidate for whom such test votes has been recorded;
- (ii) obtain the signature or thumb impression of that elector against such remarks; and
- (iii) make necessary entries regarding such test vote in item 5 in Part I of Form 17C.”.

**Rule 49T(1): .—**

- “(1) As soon as practicable after the closing of the poll, the Presiding Officer shall close the Control Unit to ensure that no further votes can be recorded and shall detach the balloting unit from the control unit, and from the printer where the printer is also used, so however, that the paper slips contained in the drop box of the printer shall remain intact”.

**56C Counting of votes-**

In sub-rule (2), after clause (a), the following proviso shall be inserted, namely:-

**“Provided that the test vote recorded, if any, for a candidate, as per item 5 in Part I of Form 17C, shall be subtracted from the number of votes recorded for such candidate as displayed on the control unit.”**

**“56D Scrutiny of paper trail-**

- (1) Where printer for paper trail is used, after the entries made in the result sheet are announced, any candidate, or in his absence, his election agent or any of his counting agents may apply in writing to the returning officer to count the printed paper slips in the drop box of the printer in respect of any polling station or polling stations.
- (2) On such application being made, the returning officer shall, subject to such

general or special guidelines, as may be issued by the Election Commission, decide the matter and may allow the application in whole or in part or may reject in whole, if it appears to him to be frivolous or unreasonable.

- (3) Every decision of the returning officer under sub-rule (2) shall be in writing and shall contain the reasons therefor.
- (4) If the returning officer decides under sub-rule (2) to allow counting of the paper slips either wholly or in part or parts, he shall-
  - (a) do the counting in the manner as may be directed by the Election Commission;
  - (b) if there is discrepancy between the votes displayed on the control unit and the counting of the paper slips, amend the result sheet in Form 20 as per the paper slips count;
  - (c) announce the amendments so made by him; and
  - (d) complete and sign the result sheet."

### **57C Sealing of Voting machines-**

- (1) After the result of voting recorded in a control unit has been ascertained candidate-wise and entered in Part II of Form 17C and Form 20 under rule 56C, the returning officer shall reseal the unit with his and the seals of the such of the candidates or their election agents present who may desire to affix the seals thereon so however that the result of voting recorded in the unit is not obliterated and the unit retains the memory of such result and where printer for paper trail is used, the returning officer shall seal the paper slips in such manner, as may be directed by the Election Commission.
- (2) The control unit and the printer slips so sealed shall be kept in specially prepared boxes on which the returning officer shall record the following particulars, namely:-
  - (a) the name of the constituency;

- (b) the particulars of polling station or stations where the control unit has been used;
- (c) serial number of the control unit and printer wherever used;
- (d) date of poll; and
- (e) date of counting.

Rule 92, sub-rule(2): In sub-rule (2), after clause (c), the following clause shall be inserted, namely:-

**“(cc) the printed paper slips sealed under the provisions of rule 57C,”**

Rule 93, sub-rule (1): In sub-rule (1), after clause (c), the following clause shall be inserted, namely:-

**“(cc) the printed paper slips sealed under the provisions of rule 57C,”**

Rule 94: In the proviso to clause (b), after the words “counterfoils of used ballot papers”, the words “and the printed paper slips, if any”, shall be inserted.

For FORM 17C, the following form shall be substituted:

[ See Annexure-22].

## 22.4 Training of Master Trainers on VVPAT:

It is necessary to provide very good quality training to all election officials. “Hands-on” training should be organized for Presiding Officers, Polling officers, Returning Officer, Assistant Returning Officers, Sector Officers and Counting Personnel.

### **Training of polling personnel and counting personnel:**

The Master Trainers will impart training to the field officials. The training should include theoretical inputs and also hands-on training. Every officer should get an opportunity to operate the EVMs with the VVPAT system and learn the process of recording the vote using VVPAT. Separate training on counting of printed ballot slips from the VVPAT system and tallying the count of printed ballot slips with the

electronic count in the EVMs using the modified Form 17C should also be given. Questions should be encouraged and all doubts should be cleared in the training. Detailed operational manual of VVPAT will be made available by the manufacturers of EVM. Copies of the operational manual should be given to all officers during training. Copies of operational manual should also be available at the polling station on the poll day. Complete training process should be videographed.

## 22.5 Awareness about use of VVPAT:

Awareness should be created amongst the political parties and electors of the Assembly Constituencies, where VVPAT is to be used, about the purpose and use of VVPAT. For this purpose, a demonstration of VVPAT system should be organized by the Returning Officers for all Candidates and Political Parties. The demonstration will be done by Engineers of VVPAT manufacturers. Demonstration of VVPAT system should also be organized for voters at suitable locations in the constituencies. A simple poster on method of voting on EVMs with VVPAT should be prepared and pasted at prominent places in all villages of the constituencies. This poster should also be pasted at two or three places in each polling station in such a manner that voters waiting in the queue are able to read the instructions in the poster. Pamphlets on the method of voting using EVMs with VVPAT should be printed and distributed to voters along with Photo Voter slips before the poll. A copy of the sample Pamphlet is attached at Annexure-23. Each voter should be given detailed instructions on the method of voting on EVMs with VVPAT on the poll day when his or her signatures/thumb impressions are obtained in the register of Voters in Form 17 A by a polling officer. The CEO, DEO and RO should also organize programmes for awareness about use of EVMs with VVPAT on Doordarshan and All India Radio.

## 22.6 First Level Checking of VVPAT system:

**The manufacturers of EVM & VVPAT should (a) put responsibility on filtering VVPATs and also depute senior engineers of the firm to supervise the juniors, who are doing First Level Checking, (b) prepare a written protocol for testing of VVPATs and send with the officials who are doing FLC, (c) Cast every VVPAT with 300 votes during FLC, and use separate roll for FLC of VVPATs, and (d) Ensure that no repairing of VVPATs is made in the field.**

The FLC of VVPAT shall be done in the presence of representatives of the National and State Political parties. During this FLC, in addition to the normal FLC procedure, political party representatives will also be asked to check the printed ballot slip in VVPAT for each vote cast, before it gets cut and falls in the drop box of the VVPAT printer, in the manner a voter is supposed to check the printed ballot slip in a real election. After the mock poll, the printed ballot slips of each VVPAT printer shall be counted to compute the result, independent of the electronic result in the CU, and the result of the printed ballot slips shall be tallied with the electronic result of the CU. The tally should be shown to those present in the FLC. The whole process shall be videographed. FLC should also be treated as an opportunity for training the representatives of the political parties in the use of EVMs with VVPAT system.

### 22.7 Preparation of EVMs and VVPAT system for Poll:



**Installation of paper roll**



**Inserting of power pack**

EVMs shall be prepared for poll according to the instructions of the Commission on preparation of EVMs for polls in the usual manner. After preparation of EVM, the VVPAT system shall be prepared for poll in the following manner as mentioned in Rule 49 B (4) (c) (i) – (iii) of the Conduct of Elections Rules, 1961: -

- a. VVPAT system consists of one VVPAT Status Display Unit (VSDU) and one VVPAT Printer unit.
- b. Fresh Paper roll shall be installed in VVPAT printer unit by following the procedure given in the user manual for VVPAT system.
- c. New power pack (battery) shall be connected to the printer of the VVPAT

unit. The door of the battery compartment must be properly shut. However, it is not sealed as the power pack can be replaced, if low battery status is indicated in VSDU, during the poll.

- d. Serial numbers and names of candidates and symbols allotted to them shall be loaded in VVPAT unit with the help of engineers of manufacturer i.e. ECIL/BEL.
- e. A test printout of the serial numbers and names of candidates and symbols loaded shall be checked with the ballot paper placed on Balloting Unit. Thereafter, switch OFF the Control Unit and **the latches of Paper Roll Compartment shall be sealed by using thread seals and address tags.**  
  
(Switching OFF of Control Unit before sealing of paper roll compartment should be ensured)
- f. Thereafter, one vote to each candidate will be given to check that the VVPAT is correctly printing the paper slips in respect of all the candidates.
- g. VVPAT units should be randomly allocated to polling stations. For this purpose, serial numbers of VVPAT printers shall be written on separate paper slips. These paper slips shall be put in a big jar and mixed. After that, the slips shall be taken out one by one and VVPAT units allocated according to polling stations.
- h. The VVPAT unit will then be kept in the carrying case provided and taken to the polling station along with the EVM.

## 22.8 Additional Polling Official:

While constituting polling parties, care should be taken to provide one extra polling official in each polling station to handle the VVPAT unit. The duty of this polling official will be to watch the VVPAT Status Display Unit (VSDU), kept on the presiding officer's table, continuously during the entire poll process. He will bring any error messages on VSDU to the notice of the Presiding Officer immediately. One additional power pack battery will be provided to every polling party. In case of low battery

error message, the battery will be changed. For any other error message, the VVPAT printer unit will be changed. It may be noted that change of paper roll is not allowed during poll.

## 22.9 Dispersal of polling parties:

At the time of dispersal of polling parties, two copies of the following shall be handed over to the Presiding Officers:

- i) Operational manual;
- ii) Trouble shooting instructions given at Annexure-24;
- iii) List of additional items of Polling materials given at Annexure-25.

## 22.10 Conduct of Mock Poll and sealing of EVM and VVPAT in the Polling Stations:

During the mock poll in the polling stations, the Balloting Unit(s) and VVPAT unit should be placed in the Voting Compartment and Control Unit and VSDU on the table of the Presiding Officer/Polling Officer who will operate the Control Unit after being properly connected. One polling officer should be present in the Voting Compartment along with polling agents to watch operations on the Balloting Unit and the printed ballot slip by the VVPAT Printer unit. This polling officer will keep a record of the votes cast. After the mock poll, Presiding Officer will



ascertain the result in the Control Unit and count the ballot slips in respect of each candidate in the presence of the polling agents and confirm that the result tallies with the votes polled in respect of each candidate. The Presiding Officer shall ensure that the data of mock poll is cleared in the Control Unit, without fail, and also remove all the printed paper (ballot) slips from the drop box in the VVPAT unit. The printed paper slips of the mock poll should be stamped on their back side with rubber stamp having inscription “MOCK POLL, SLIP” before keeping and sealing these printed paper slips in the thick black envelope supplied for the purpose. The envelope

will be sealed with the seal of the presiding officer. The Presiding Officer and the polling agents present shall put their signatures on the envelope. The number and name of the polling station and number and name of Assembly Constituency alongwith the date of poll shall be written on the Envelope. Words- “Printed paper slips of Mock Poll” shall also be written on the envelope. The envelope shall then be kept in the special plastic box provided for the purpose. The plastic box shall be sealed with a Pink Paper Seal placed all around in such a manner that opening of the box shall not be possible without breaking the seal. The number and name of the polling station and number and name of Assembly Constituency alongwith the date of poll shall be written on the plastic box. The Presiding Officer and Polling Agents present shall put their signatures on the pink paper seal. This plastic box containing printed paper slips of the mock poll shall be kept along with other documents relating to elections by the Returning Officer and shall be preserved till the period of filing of Election Petitions is over or in case an election petition is filed, till the final disposal by the Competent Court. Polling agents present will be allowed to verify that the drop box of VVPAT unit is now empty. Thereafter, Presiding Officer will prepare and sign the mock poll certificate (Annexure-15) in the revised format of Mock Poll Certificate enclosed herewith and seal the Control Unit as per procedure laid down in the Presiding Officers’ Handbook. The Presiding Officer shall also prepare the VVPAT system as under:

- (i) The lower part of the VVPAT unit, i.e. drop box, shall be sealed with the thread and Address Tag before actual poll starts.
- (ii) After that, BU and VSDU shall be connected to the VVPAT printer and connect the VVPAT printer to the Control Unit.
- (iii) Switch ON the Control Unit, after making all connections.

**This is a very critical step and this should be emphasized during training.** Observer should visit maximum number of polling stations on the poll day to check that everything is being done in the manner prescribed by the Commission.

#### **22.11 Complaint about incorrect printing of particulars on paper slip:**

If any voter alleges about the wrong printing of particulars of a candidate and/or



symbol of that candidate on paper slip printed by the printer on pressing of concerned blue (candidate) button on the Balloting unit to which the printer is connected, the Presiding Officer of the polling station should provide him a ‘Form of Declaration’ (Annexure-26) to lodge a complaint and follow the procedure prescribed under rule 49MA, which reads as under:

**“49MA. Procedure in case of complaint about particulars printed on paper slip.-**

- (1) Where printer for paper trail is used, if an elector after having recorded his vote under rule 49M alleges that the paper slip generated by the printer has shown the name or symbol of a candidate other than the one he voted for, the presiding officer shall obtain a written declaration from the elector as to the allegation, after warning the elector about the consequence of making a false declaration.
- (2) If the elector gives the written declaration referred to in sub-rule (1), the presiding officer shall make a second entry related to that elector in Form 17A, and permit the elector to record a test vote in the voting machine in his presence and in the presence of the candidates or polling agents who may be present in the polling station, and observe the paper slip generated by the printer.
- (3) If the allegation is found true, the presiding officer shall report the facts immediately to the returning officer, stop further recording of votes in that voting machine and act as per the direction that may be given by the Returning Officer.
- (4) If, however, the allegation is found to be false and the paper slip so generated under sub-rule (1) matches with the test vote recorded by the elector under sub-rule (2), then, the presiding officer shall-
  - (i) make a remark to that effect against the second entry relating to that elector in Form 17A mentioning the serial number and name of the candidate for whom such test votes has been recorded;
  - (ii) obtain the signature or thumb impression of that elector against such remarks; and

- (iii) make necessary entries regarding such test vote in item 5 in Part I of Form 17C.”.

## 22.12 Action in case of certain contingencies during poll:

Certain contingencies may arise during the polling process, which may require certain actions. These are as follows: -

- a. In case the CU or the BU does not work properly, replacement of the whole EVM including CU, BU and VVPAT is required. *No mock poll is required to be taken.*
- b. In case the VSDU is showing “Low Battery”, the power pack battery of VVPAT should be replaced. **It should be ensured that before taking out the power pack battery of VVPAT, control unit must be switched OFF and after installing new power pack battery in VVPAT, control unit should be switched ON. Control Unit should not be switched ON without installing power pack in VVPAT.**
- c. In case there is any other error, like “Paper Low” error, the VVPAT will stop printing and the error shall be displayed on the VSDU. In such case the VVPAT unit is to be replaced. *No mock-poll is required to be taken.* Therefore, if VVPAT has not printed the paper slip, or the printed paper slip has not been cut, the last voter whose paper slip has not been printed by VVPAT or has not been cut should be allowed to cast his vote after the VVPAT has been replaced. In case the printed paper slip has not been cut and is hanging from the paper roll, no effort should be made to make it fall into the drop box. It should be allowed to remain hanging as it means that the vote has not been recorded in Control Unit and as it is not to be counted at the time of counting of the printed-paper slips. The details of such an occurrence should be clearly recorded in the Presiding Officer’s dairy in the following format: -
  - i. The date and time of the occurrence.
  - ii. The name of the voter and his serial number in the part in the electoral roll, who was allowed to cast his vote after replacement of VVPAT.

- iii. Whether the voter cast his vote after replacement of VVPAT or went away without casting his vote.
- iv. The Total number of votes cast before the occurrence.

### **22.13 Counting of paper slips of VVPAT:**

Counting of votes shall be done according to rule 56C of the Conduct of Elections Rules, 1961. After the entries made in the result sheet of election are announced by the Returning Officer, any candidate, or in his absence, his election agent or any of his counting agents may apply in writing to the Returning Officer to count the printed paper slips of VVPAT unit in respect of any polling station or all polling stations, giving the reasons for such requests. On such application being made, the Returning Officer shall pass a speaking order on whether the counting of paper slips shall be done or not. While deciding the matter the Returning Officer shall give due consideration to the following: -

- a) Whether the total number of votes polled in that polling station is more or less than the margin of votes between winning candidate and candidate making the application,
- b) Whether EVM met with any defect and was replaced at that polling station during poll,
- c) Whether there was any complaint about VVPAT not printing the paper slips or complaints under rule 49MA by any voter, in that polling station during the poll.

If the Returning Officer decides to allow counting of the paper slips of any polling station or all polling stations, such decision of the Returning Officer shall be recorded in writing and shall contain the reasons therefor.

The following procedures shall be strictly followed in case it is decided to count the printed slips of VVPAT: -

- a. VVPAT unit(s) of the respective polling station(s) shall be brought to the Counting table(s).
- b. Address tag(s) of the drop box of the VVPAT unit(s) shall be cross checked to ascertain that it actually pertains to the same polling station, address tag of VVPAT unit should be removed and ballot paper slips shall be taken out from the drop box. Care should be taken that no printed paper slip is left in the drop box. Empty drop box should be shown to all counting agents.
- c. In case a VVPAT unit was replaced during poll at any polling station, all the VVPAT units used at that polling station should be brought to the counting table and printed paper slips from all of them should be taken out before beginning the counting of printed paper slips for that polling station.
- d. In case a VVPAT unit was replaced, it may so happen that an uncut fully or partially printed paper slip is hanging and has not got cut and dropped in the drop box and still connected to the paper roll. This uncut printed paper slip should not be torn and should not be counted because the vote is not recorded electronically in the CU unless the printed paper slip is cut. In such an event, the last voter whose printed paper slip was not cut would have been given an opportunity to cast his vote after replacement of VVPAT and the printed paper slip of the vote cast by him shall be in the next VVPAT printer used in that polling station.
- e. The drop box of the VVPAT printer will also have slips of self test report. These are easily identified, as they do not have either the name or the symbol of any candidate and are of larger length. These self-test report slips are to be preserved alongwith the printed-paper slips as part of the record but they are not to be counted.
- f. Pigeonholes will be prepared to put ballot paper slips of the respective candidates.

- g. After all the ballot paper slips are put in the respective pigeon holes, bundles of 25 paper slips of respective candidates will be prepared for counting purpose.
- h. Printed-paper slips will then be counted by the counting staff.
- i. The result of the count of ballot slips will be announced loudly in the counting hall and shown to the counting agents.
- j. If there is discrepancy between the count of votes displayed on the control unit and the count of printed-paper slips in respect of any Polling Station, the result sheet will be amended as per the printed -paper slips count.
- k. The Returning Officer shall announce the amendments so made by him and declare the result.

#### **22.14 Sealing of VVPAT units after counting of votes:**

After the result is announced, whether the printed paper slips of VVPAT were counted or not, the printed paper slips will be taken out of the drop box of the VVPAT Printer unit and stored in the following manner: -

- a. The printed-paper slips shall be kept in a paper envelope made of thick black paper. The envelope shall be sealed with red wax with the bilingual secret seal of the Commission provided to the RO for sealing of the documents. Following shall be written on the envelope: -
  - i. The name of election;
  - ii. The number and name of Assembly Constituency;
  - iii. The particulars of polling station in respective boxes;
  - iv. Unique serial number of the Control Unit & VVPAT units in respective boxes;
  - v. Date of poll; and
  - vi. Date of counting.

- b. The envelope will then be kept in a special plastic prepared box supplied by the manufacturers of VVPAT for this purpose. The plastic box shall be sealed with a pink paper seal in such a manner that the box cannot be opened without breaking the seal. The Returning Officer shall put his signature on the pink paper seal. Following shall be written on the plastic box: -
- i. The name of election;
  - ii. The number and name of Assembly Constituency;
  - iii. The particulars of polling station in respective boxes;
  - iv. Unique serial number of the Control Unit & VVPAT units in respective boxes;
  - v. Date of poll; and
  - vi. Date of counting.
- c. These Plastic boxes shall be kept with all the statutory documents relating to that election till the statutory time limit for filing an election petition is over or in case where an election petition is filed till the final disposal of the election petition by the competent Court. The plastic boxes shall not be opened or destroyed without obtaining the prior permission of the Commission.
- d. The VVPAT printers after taking out the printed paper slips shall be kept in a separate strong room and should not be kept in the strong room where EVMs are stored, so that even if any election petition is filed from the constituency, the VVPAT units can be taken out for use, if required, without opening the strong room having EVMs.

It should be ensured that the unused portion of Thermal Paper Roll and Battery (Power Pack) are taken out from the VVPAT, before keeping the VVPAT units in the Strong Room.

22.15 VVPAT BROCHURE FOR PRESIDING OFFICERS



## ***Voter Verifiable Paper Audit Trail (VVPAT)***

The VVPAT enables the voter to physically verify the vote cast on the EVM. It consists of the Printer Unit to print the voter's selection and the VSDU (VVPAT Status Display Unit) to display the error messages of VVPAT during poll.

The VVPAT prints the selection of the voter on a two inch long slip of paper called Ballot Slip. The ballot slip will display:

1. The serial number of the candidate
2. The name of the candidate
3. The corresponding symbol

The paper slip is displayed behind a transparent window for seven seconds before it is automatically cut and collected in the sealed Ballot compartment below. The VVPAT battery and paper roll are designed for printing minimum 1500 Ballot slips for each election.

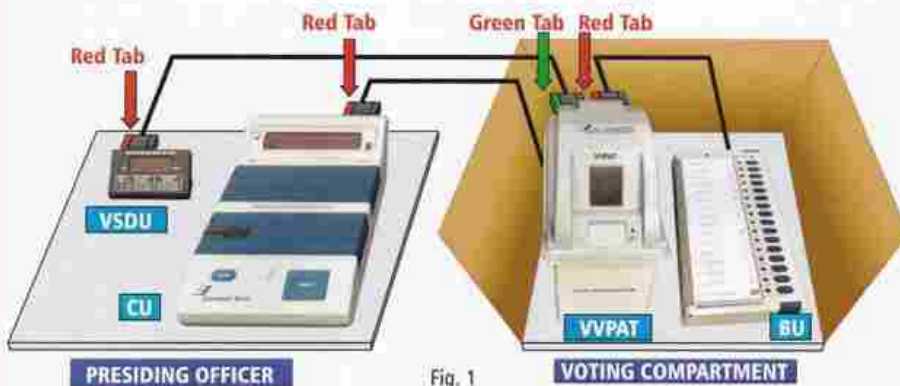

Fig. 1



# VVPAT Components

The VVPAT system consists of following accessories.

1

## VVPAT UNIT

The VVPAT printer prints the ballot slips and collects them in a secure sealed box. The VVPAT comes with an attached cable which is used to connect to the CU.



Connector with Red/Black latch

2

## VVPAT STATUS DISPLAY UNIT (VSDU)

VVPAT Status Display Unit (VSDU) is used to indicate the VVPAT system status to the Presiding officer. The VSDU displays **PRINTER ERRORS, LOW BATTERY** and also the suggested action to be taken.

Connector with Blue/Green latch



3

## INTERCONNECTING CABLE TO VSDU

The Interconnecting Cable connects the VSDU to the VVPAT unit



VVPAT Unit with 5 meter cable ( to connect to CU)

4

## BATTERY PACK FOR VVPAT

A Battery Pack for running the VVPAT is inserted at the appropriate compartment in the VVPAT unit

Battery pack for the VVPAT unit



5

## PAPER ROLL



Paper Roll for Printing of Ballots

Thermal Paper Roll

6

## CARRY CASE

A Strong Case to carry the whole VVPAT system in a secure way

VVPAT Carrying Case



# VVPAT Operation

Commissioning of VVPAT by Presiding Officer (PO)  
at Polling Station on day of poll

## STEP 1

### Preliminary Checks

1. At the polling station, remove the VVPAT and VSDU with cables carefully from carrying case
2. Check for proper condition of the VVPAT unit, VSDU unit, connecting cables and connectors
3. Sealing should be intact for paper roll compartment.
4. Check and ensure that the ballot compartment is empty. All paper slips or ballot slips should be removed from inside the compartment.

## STEP 2

### VVPAT setup and connection with EVM System

- Place CU & VSDU and BU & VVPAT as per (Fig. 1)
- Connect the VVPAT unit with EVM system as per steps below
- Close cable compartments after connecting the cables



All connection of EVM & VVPAT shall be done only in Power off condition.

**STEP 3**

**Mock Poll Procedure**

To conduct a Mock Poll at polling booth follow the below process

**SETUP**

1. Power ON the CU.
2. ON lamp will glow on CU and VVPAT.
3. VVPAT prints Power ON Self Test (POST) slip. The POST slip is seen through the window and cuts and falls down.
4. In case of any error in the VVPAT, corresponding error is printed in the POST slip. In case POST slip does not cut, replace VVPAT with good one
5. Now the EVM – VVPAT system is ready for voting process.

Ballot Unit Ready for Voting



Red Light Indicates Register of Vote  
Candidate Button



**MOCK VOTING**

Follow the standard mock poll procedure for CU/BU as per the EVM instruction booklet.

1. The ballot process is initiated and each polling agent is allowed to vote for the candidate of choice.
2. VVPAT prints the ballot slip containing the serial number of the candidate, name of the candidate and corresponding party symbol.
3. The printed slip is held for 7 seconds and then cut and subsequently falls into the ballot collection drop box.
4. Repeat this ballot process by voting for each contesting candidate and verify the correctness of the printed ballot slips.
5. Keep a careful manual record of the votes polled in respect of each candidate.
6. Press the CLOSE button on CU.



Voter Sees Candidate Name, Number & Symbol Printed



At least 50 votes should be cast during mock poll

## MOCK POLL VERIFICATION

1. Press the RESULT button on CU and manually record the result data displayed by CU.
2. Press the CLEAR button on CU and observe TOTAL should be zero in the CU.
3. Switch OFF the CU.
4. Open the ballot compartment door of the VVPAT and collect the VVPAT ballot slips.
5. Segregate these ballot slips as per the party symbol and record the result of the counted slips. Keep aside the POST slip(s).
6. Compare the VVPAT result data with the CU result data. Both must tally candidate wise.
7. After ensuring the correctness of the EVM-VVPAT system, remove the mock poll printed ballot slips and store separately.



Fill mock poll certificate carefully and correctly



Ensure that the ballot compartment is empty before actual poll.

### STEP 4

#### *Sealing of ballot slips compartment after mock poll*

- The presiding officer should ensure that the ballot slips compartment of VVPAT is empty and does not contain any paper slips.
- The presiding Officer is required to seal the ballot slips compartment door in presence of polling agents. Sealing procedure is same as followed for the CU.

## STEP 5

### Actual Poll Procedure

*After ensuring that all seals are in proper condition and that the CU, VSDU, BU and VVPAT are placed as in Fig 1, power ON the CU.*

- The presiding officer should ensure that the VVPAT should be in ON condition by checking the power ON LED.
- Continue the actual polling as per the standard procedure in the case of EVM.
- Polling officer shall be monitoring the Status of VVPAT through the VSDU messages.
- If the VVPAT stops printing and shows error in the VSDU the VVPAT Unit should be replaced by another VVPAT Unit. The voter should be asked to vote again on the replaced system.



In the event of any failure in the VVPAT the unit should be replaced with a good one.



In case of 'LOW BATTERY' indication by VSDU the battery Should be replaced by a new one.

## STEP 6

### Closing of Poll Procedure

*After completion of actual poll take the following steps*

1. Press the close button on CU.
2. Switch OFF the CU.
3. Disconnect the VVPAT cable connected to CU.
4. Disconnect the VSDU cable connected to VVPAT
5. Disconnect the BU cable connected to VVPAT.

**STEP 7**

**VVPAT Packing Instructions before  
dispatch to strong room/counting center**

1. Keep VVPAT with its cable and VSDU with its cable in the VVPAT carrying case.
2. Care should be taken while winding of VVPAT and VSDU cables.
3. Seal the carrying case in the presence of Presiding Officer and polling agents.



**Election Commission of India**

Nirvachan Sadan, Ashoka Road, New Delhi-110001

Tel.: +91-11-23717391-98, Fax: +91-11-23713412 [www.eci.nic.in](http://www.eci.nic.in)

## 22.16 How to Vote using EVM & VVPAT

# HOW TO CAST YOUR VOTE

**1 ENTER THE BOOTH**  
The Presiding Officer will enable the ballot Unit while you enter the polling compartment.

**2 CAST YOUR VOTE**  
Press the Blue Button on the Ballot Unit against the name /symbol of candidate of your choice.

**3 SEE THE LIGHT**  
The red light against the name /symbol of candidate chosen will glow.

**4 SEE THE PRINT**  
The Printer will print a ballot slip containing Serial Number, Name and Symbol of the chosen Candidate as shown.

See the print through the glass, as the printout will not be given to you.

**NOTE!**  
If you do not see the ballot slip and hear the loud beep please contact the Presiding officer.

**ELECTION COMMISSION OF INDIA** [www.eci.nic.in](http://www.eci.nic.in)

## 22.17 How to Vote using EVM & VVPAT

# HOW TO CAST YOUR VOTE USING EVM

**1** Go to Voting Booth

When the Presiding officer says – Enter Voting booth – Check to See the Green Ready Light is On

**2** Choose Candidate & Cast your Vote

Press Blue Button next to the Candidate of Choice

**3** See the light

Confirm that your Vote has registered by Seeing Red light Glowing & Hearing Beep Sound

**NOTE!**  
If you do not see red light glow and hear the loud beep please contact the Presiding officer.

**ELECTION COMMISSION OF INDIA**

[www.eci.nic](http://www.eci.nic)



## CHAPTER - 23

### VARIOUS TYPES OF SEALS USED FOR SEALING EVMs & VVPATs

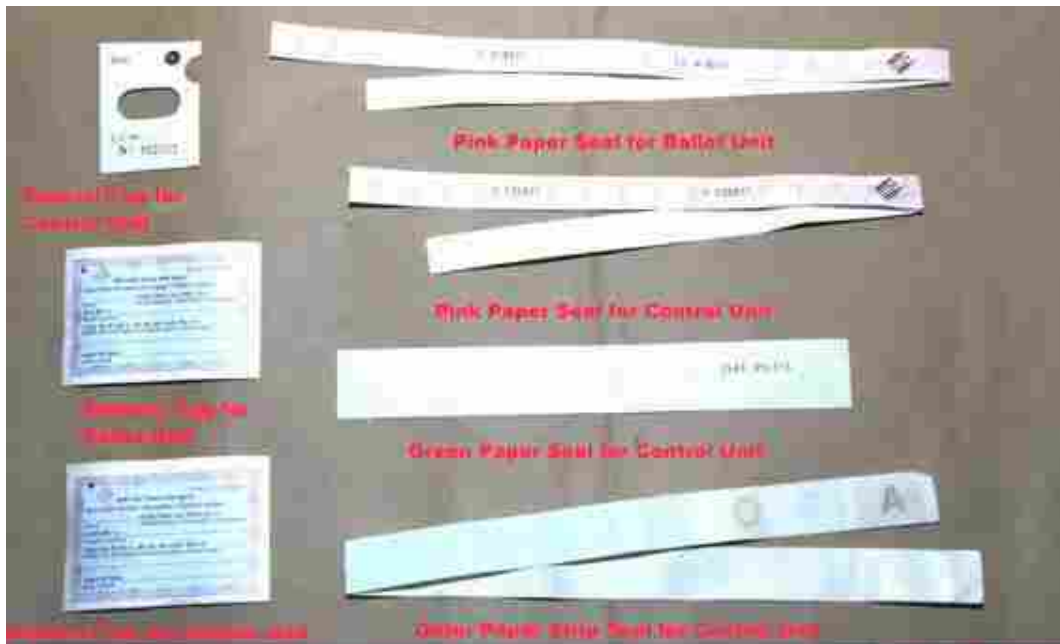

Various Type of Seals used for Sealing Electronic Voting Machine

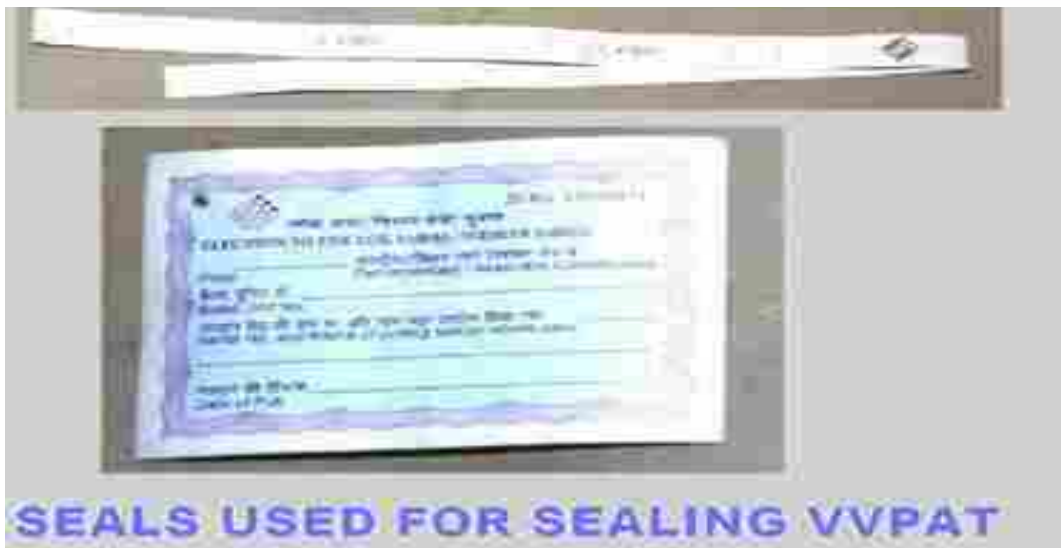

## 23.1 SEALING OF EVMs

### **AT THE TIME OF FIRST LEVEL CHECKING OF EVMs (FLC)**

Sealing of plastic cabinet of Control Unit of EVMs with pink paper seal:



After First Level Checking of the EVMs, the Control Unit is sealed with the 'Pink Paper Seal' supplied by the Nasik Security Press in the presence of the representatives of the Political Parties present at the time of FLC. The Pink Paper Seal is affixed on the portion between the Candidate Set Section and the Result Section of the Control Unit.

### **AT THE TIME OF PREPARATION OF EVMs (CANDIDATE SET)**

(a) Sealing of ballot paper screen of BU with thread and address tag



After the ballot paper is firmly fixed and the ballot paper screen is pressed fit on the upper side of the top cover. The screen is to be sealed on the inner side of the top cover. This is done by passing the thread through the two holes on the screen specially provided for the purpose using address tag showing the particulars of the election with the seal of the Returning Officer.

(b) Sealing of plastic cabinet of BU with thread and address tag

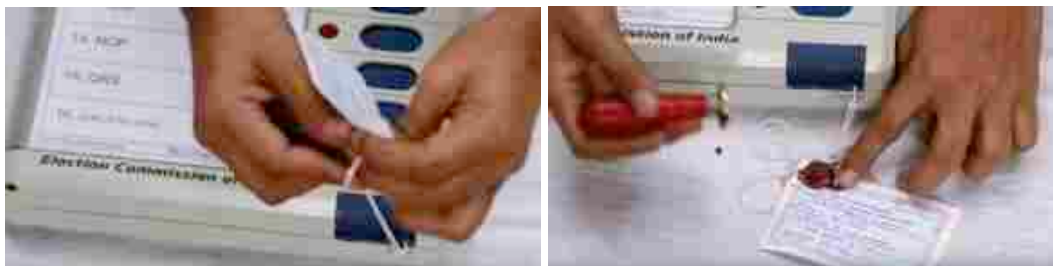

After unmasking required number of candidate buttons, the upper cover of the BU is sealed by passing a thread through the holes provided on the top and bottom end at right side using address tags showing the particulars of the election with the seal of the Returning Officer.

(c) Sealing of plastic cabinet of BU with pink paper seal:



In addition, the BU is sealed with a special “pink paper seal” supplied by India Security Press, Nasik, in the presence of candidates or their representatives at the time of preparation of EVMs. Pink paper seal is fixed at the lower most portion of the BU in such a manner that no candidate’s button or candidate’s name or symbol is hidden by the seal.

(d) Sealing of Candidate Set Section of CU with thread & address tag



Sealing of inner cover of Candidate Set Section



Sealing of outer cover of Candidate Set Section

After Candidate set, inner and outer covers of the Candidate Set Section of CU are sealed by passing a thread through hole provided on the left side using address tags showing the particulars of the election with the seal of the Returning Officer.

### **AT THE POLLING STATIONS ON POLL DAY**

#### **Sealing of EVMs after Mock poll and before starting actual poll on poll day**

After mock poll and clearing mock poll data, switch off the power switch of Control Unit for sealing Result Section of the CU.

#### **(a) Fixing of Green Paper Seal and closing of inner compartment**



Green paper seal has to be passed through the frame provided for the purpose on the inner side of the door of the inner compartment of the Result Section. After fixing the seal, the door of the inner compartment is to be closed in such a manner that the two ends of the paper seal project outwards from the sides of the inner compartment.

**(b) Sealing of inner door compartment (inner Result Section) with Special Tag**



Inner door of the Result Section is sealed by passing a thread through hole provided on the left side using Special Tag showing the particulars of the election with the seal of the Presiding Officer.

**(c) Sealing of outer door Result Section of CU with thread seal using Address Tag and Outer Paper Strip Seal**



The outer cover of the Result Section of the CU has to be pressed for closing this section. The outer cover of the Result section is sealed by passing a thread through hole provided on the left side using Address Tag showing the particulars of the election with the seal of the Presiding Officer.

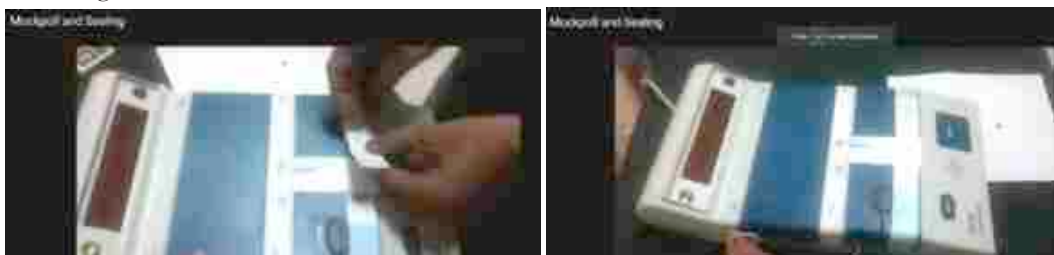

Thereafter, Outer Paper Strip Seal (ABCD seal) is used to get glued to the Green paper seal.

**(d) Sealing of carrying case of EVM**



After completion of poll, BU and CU are kept in the respective carrying case. The carrying cases are sealed by passing a thread through holes provided using Address Tags showing the particulars of the election with the seal of the Presiding Officer.

**SEALING OF EVMs AFTER COUNTING OF VOTES**



After completion of counting, all Control Units, whether result was retrieved from it or not, is kept back inside its carrying case. The carrying cases are then sealed once again by passing a thread through hole provided on the carrying cases using Address Tag showing the particulars of the election with the seal of the Returning Officer.

VOTER VERIFIABLE PAPER AUDIT TRAIL (VVPAT):

SEALING OF PAPER ROLL COMPARTMENT AT THE TIME OF PREPARATION OF VVPAT



After installation of paper roll in the paper roll compartment of VVPAT, the latches of Paper Roll Compartment is by passing a thread through holes provided on the latches using Address Tag showing the particulars of the election with the seal of the Returning Officer.

**(Switching OFF of Control Unit before sealing of paper roll compartment should be ensured)**

### **AT THE POLLING STATIONS ON POLL DAY**

- (a) **Sealing of plastic box having mock poll printed ballot slips with Pink Paper Seal**



After the mock poll, Presiding Officer removes all the printed paper (ballot) slips from the drop box in the VVPAT unit. The printed paper slips of the mock poll, should be stamped on their back side with rubber stamp having inscription “MOCK POLL SLIP” before keeping and sealing these printed paper slips in the thick black envelope supplied for the purpose. The envelope is sealed with the seal of the presiding officer.



The envelope shall then be kept in the special plastic box provided for the purpose. The plastic box is sealed with a Pink Paper Seal placed all around in such a manner that opening of the box shall not be possible without breaking the seal.

**(b) Sealing of drop box of VVPAT with thread using Address Tag**



Thereafter, the lower part of the VVPAT unit, i.e. drop box, is sealed with the thread and Address Tag before actual poll starts.

**(c) Sealing of carrying case of VVPAT**

After completion of poll, VVPAT & VSDU are kept in the carrying case. The carrying case is sealed by using thread and Address Tag showing the particulars of the election with the seal of the Presiding Officer.

**SEALING OF PRINTED PAPER SLIPS OF VVPAT AFTER COUNTING OF VOTES**

After the result is announced, whether the printed paper slips of VVPAT were counted or not, the printed paper slips are taken out of the drop box of the VVPAT Printer unit and stored in the following manner: -

- a. The printed-paper slips are kept in a paper envelope made of thick black paper. The envelope is sealed with red wax with the bilingual secret seal of the Commission provided to the RO for sealing of the documents.
- b. The envelope is then kept in a special plastic prepared box supplied by the manufacturers of VVPAT for this purpose. The plastic box is sealed with a pink paper seal in such a manner that the box cannot be opened without breaking the seal.



## CHAPTER - 24

### REPAIRING OF DEFECTIVE EVMs & VVPATs

**24.1** The defective EVMs are sent to the factory of the concerned manufacturers of the EVMs, namely, BEL & ECIL or collected at a centralized location in the State HQs concerned for necessary repairs. Following protocol is to be strictly followed for defective EVMs: -

24.1.1 During First Level Checking of EVMs/VVPATs, no electronic repair is to be carried out. However, mechanical repairs i.e. replacement of broken/damaged switches, buttons, latches, hood, cable, RTC cell, spindle etc. for which no soldering is required shall be done during FLC. For this purpose, engineers deputed for FLC shall have adequate number of spares with them for mechanical repairs of EVMs/VVPATs. Further the engineers deputed for FLC of EVMs/VVPATs shall also maintain list of the defective units (containing Unit ID of BU/CU/VVPAT with defect observed). Repairing of defective EVMs shall only be done after counting is over, at a centralized location in the State.

24.1.2 For EVMs found defective during Preparation, mock poll, poll, counting of votes, the following procedure shall be followed: -

- (a) Immediately after completion of mandatory period of 45 days from the date of declaration of the result for filing Election Petitions, the details of the Election Petition/Court Cases pertaining to the election shall be obtained from the concerned High Court/Court.
- (b) After ascertaining the position of EP/court cases from the concerned court, within 10 days all the defective EVMs (along with list containing unique ID of BU/CU), which are not involved in any EP/court cases, shall immediately be got repaired.
- (c) Strong Room shall not be opened in which the defective EVMs pertaining to any EP/court case are kept. After final disposal of the EP/Court case. The defective EVMs collected at State HQs for repairs, shall be got repaired within one month.

- 24.1.3 For VVPATs which fail during Preparation, mock poll, or poll, a list shall be prepared on the basis of defects. The VVPATs which can be repaired in the field shall be shifted to a centralized location in the State for repairs and shall be got repaired within one month. The VVPATs which are required to be sent to the factory for repairs, shall be sent to the manufacturer concerned (along with list containing unique ID of defective VVPATs) for repairing, within 10 days after counting of votes.
- 24.1.4 The manufacturers shall not return the repaired EVMs/VVPATs to the respective State/UT. These repaired EVMs/VVPATs shall be kept in the factory. CEOs/DEOs are not required to take back the EVMs/VVPATs sent to the factory for repairs. **Further allocation of these repaired EVMs/VVPATs will be done by the Commission only.**
- 24.1.5 The manufacturers will furnish a report of the repaired EVM/VVPAT to the Commission.
- 24.1.6 As the EVMs/VVPATs, repaired at factory, will not be returned to the sender State/UT, therefore, shifting of these defective EVMs/VVPATs to the manufacturers is explicitly required to be done through ETS by the concerned Chief Electoral Officer of the concerned State/UT, to ensure that EVM/VVPATs, that are not available in the Warehouse of the State/UT, do not reflect in their Warehouse and also to avoid formation of conflict in the ETS.

No electronic repair to be done during FLC.

Only mechanical repairs can be done during FLC.

Repairing of defective EVMs shall only be done after counting is over, at a centralized location in the State.

Shifting of defective EVMs/VVPATs to the manufacturers is explicitly to be done through ETS by the State/UT, to ensure that EVM/VVPATs, that are not available in the Warehouse of the State/UT, do not reflect in their Warehouse and also to avoid formation of conflict in the ETS.

## Annexure-1

### (Master Stock Register) Part- A (Control Unit)

Name of State/Union Territory:

Name of District:

Name of sub-division/taluka:

Address of Warehouse:

Box No.	CU ID No.	Name of Manufacturer	Year of Manufacture	Date of Receipt	Receipt Challan No.	Date on receipt challan	Name and designation of receiver	Signature of receiver	Signature of Warehouse-in-charge	Remarks
1	2	3	4	5	6	7	8	9	10	11

### Part-B (Balloting Unit)

Box No.	BU ID No	Name of Manufacturer	Year of Manufacture	Date of Receipt	Receipt Challan No.	Date on receipt challan	Name and designation of receiver	Signature of receiver	Signature of Warehouse-in-charge	Remarks
1	2	3	4	5	6	7	8	9	10	11

**(Physical Verification Report)**

**Name of State/Union Territory:**

**Name of District:**

Name of warehouse		Location of warehouse		No. of Control Units in warehouse as mentioned in Master Stock Register		No. of Control Units physically verified		No. of Control Units not in warehouse as mentioned in Master Stock Register		No. of Balloting Units in warehouse as mentioned in Master Stock Register		No. of Balloting Units physically verified		No. of Balloting Units not in warehouse as mentioned in Master Stock Register	
		BEL	BEL	BEL	BEL	BEL	BEL	BEL	BEL	BEL	BEL	BEL	BEL	BEL	BEL

Note- Reasons for EVM not available in warehouse shall be clearly mentioned in the report.

**(Signature of District Election Officer)**

**Annexure-3**

**(Physical Verification Report)**

**Name of State/Union Territory:**

**Name of District:**

Name of warehouse		Location of warehouse		No. of Control Units in warehouse		No. of Control Units physically verified and FLC done		No. of Control Units found defective during FLC		No. of Balloting Units in warehouse as mentioned in Master Stock Register		No. of Balloting Units physically verified and FLC done		No. of Balloting Units found defective during FLC	
		BEL	BEL	BEL	BEL	BEL	BEL	BEL	BEL	BEL	BEL	BEL	BEL	BEL	BEL

Note- Reasons for EVM not available in warehouse shall be clearly mentioned in the report.

**(Register for First Level Checking of EVMs)**

**Name of State/UT:**

**Name of District:**

**Address of FLC hall:**

**Date:**

S.No.	Name of National/State Party	Name of representative of political party with party affiliation	Identity document No. with date	Signature of representative	Remarks, if any.

Note: If the representative of a party is absent the proof of due service of notice to the party should be pasted in the register.

(Name and signature of engineers of BEL/ECIL with ID No.)

(Name, designation, signature of officers nominated by District Election Officer)

**Annexure - 5**

**Certification of EVMs by BEL/ECIL)**

**Name of State/UT:**

**Name of District:**

**Address of hall:**

**Date:**

It is certified that tests prescribed by BEL/ECIL to ascertain that all components are original were carried out on the EVMs listed below on..... (date). On the basis of these tests it is certified that all components of the EVMs listed below are original.

<b>CU Identification No.</b>	<b>BU Identification No.</b>

**(Name & signature of BEL/ECIL engineers with ID No.)**

**Annexure - 6**

**(Mock Poll certification during First Level Checking of EVMs)**

**Date:.....**

**Name of State/UT:**

**Name of District:**

**Address of hall:**

It is certified that I have done mock poll on..... EVMs and I am fully satisfied with the functioning of EVMs.

S.No.	Name of National/State Party	Name of representative of political party with party affiliation	Identity document No. with date	Signature of representative	Remarks, if any.



**Annexure - 7**

**(Mock Poll certification during First Level Checking of EVMs)**

**Date:.....**

**Name of State/UT:**

**Name of District:**

**Address of hall:**

It is certified that a printout of the result of mock poll as well as a sequential print out of every vote polled during the mock poll has been taken out from ..... EVMs picked up by me. There are no discrepancies between the votes polled during the mock poll and result in the print out.

S.No.	Name of National/State Party	Name of representative of political party with party affiliation	Identity document No. with date	Signature of representative	Remarks, if any.

**Annexure - 8**

**(Register for Sealing of Control Unit of EVMs using Pink Paper Seal)**

**Date:.....**

**Name of State/UT:**

**Name of District:**

**Address of FLC hall:**

**Date:**

It is certified that the sealing of the Control Units using Pink Paper Seals has been done in my presence. I have put my signature on the Pink Paper Seals after sealing of the Control Units and I am satisfied with the sealing of the Control Units.

Sl. No.	Unique ID No. of Control Unit	Pink Paper Seal Number

S.No.	Name of National/State Party	Name of representative of political party with party affiliation	Identity document No. with date	Signature of representative

**(Name, designation, signature of officers nominated by District Election Officer)**

Annexure - 9

Voting Compartment – Dimensions & Cascading of Balloting Units

ON ONE SIDE - FACING THE WEB CAMERA



Name of State/UT:

AC/PC Name:

AC/PC Number:

Date of Poll:

Polling Station Name:

Polling Station Number:

ON REMAINING TWO SIDES OF THE VOTING COMPARTMENT



भारत निर्वाचन आयोग

मतदान कम्पार्टमेंट

ELECTION COMMISSION OF INDIA

VOTING COMPARTMENT

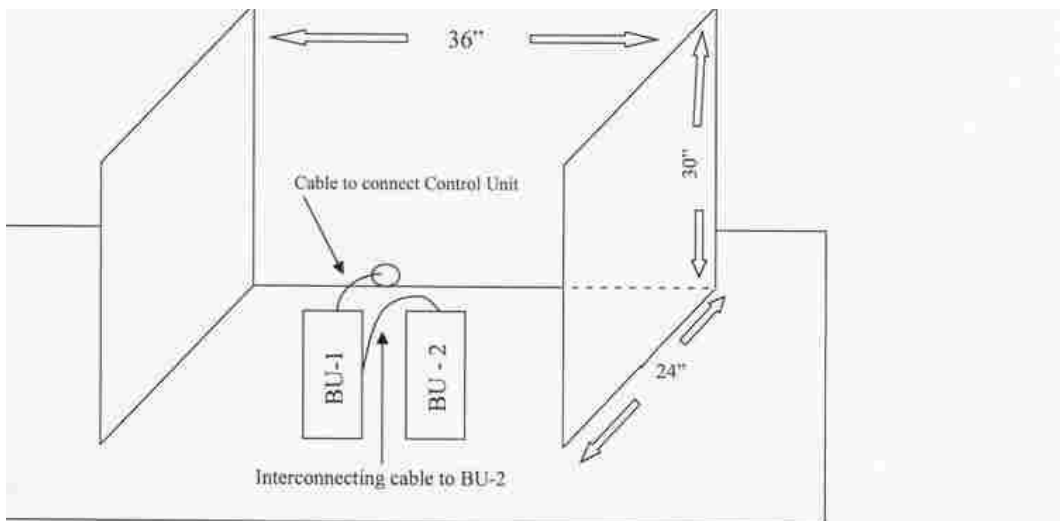
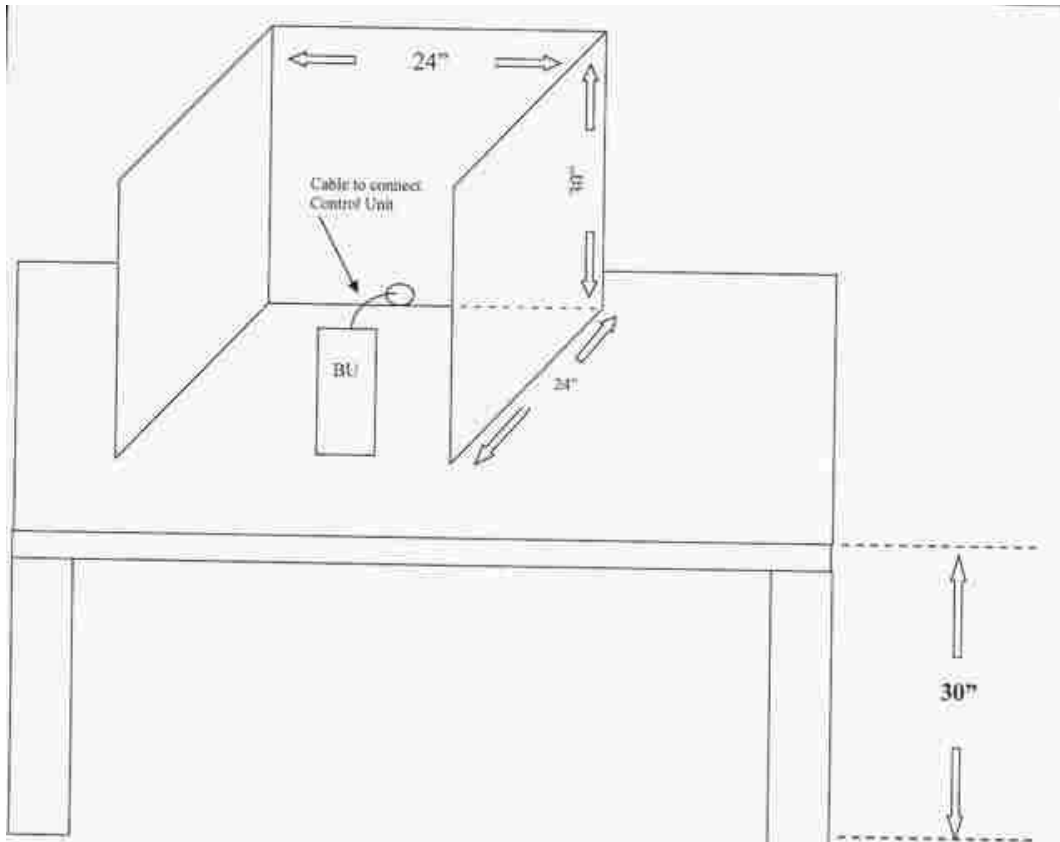

**CASCADING OF TWO BALLOT UNITS**

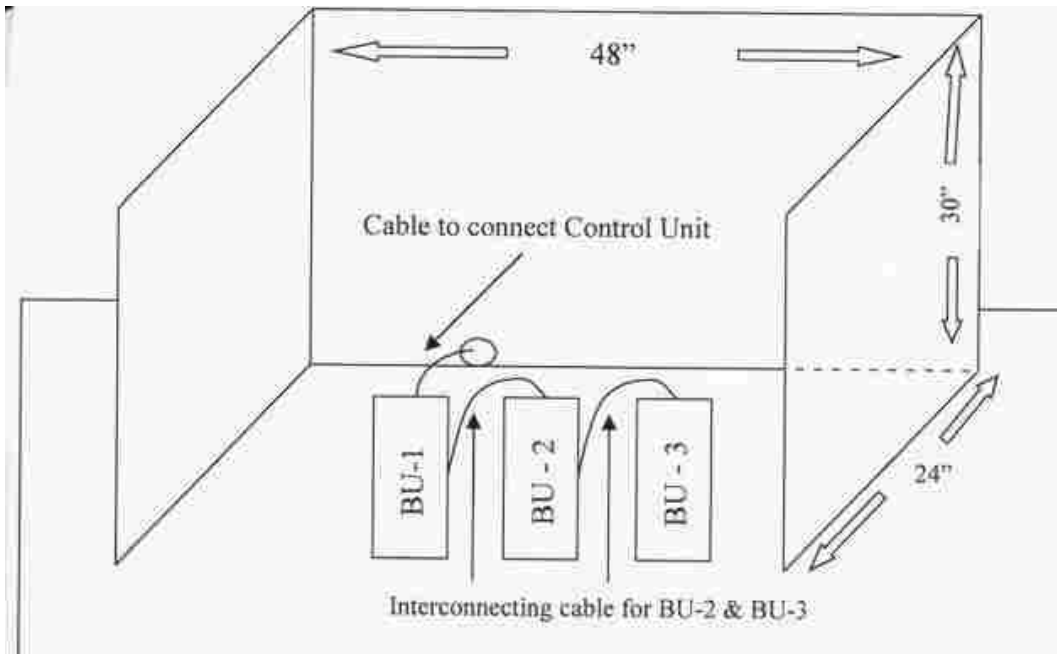

### CASCADING OF THREE BALLOTING UNITS

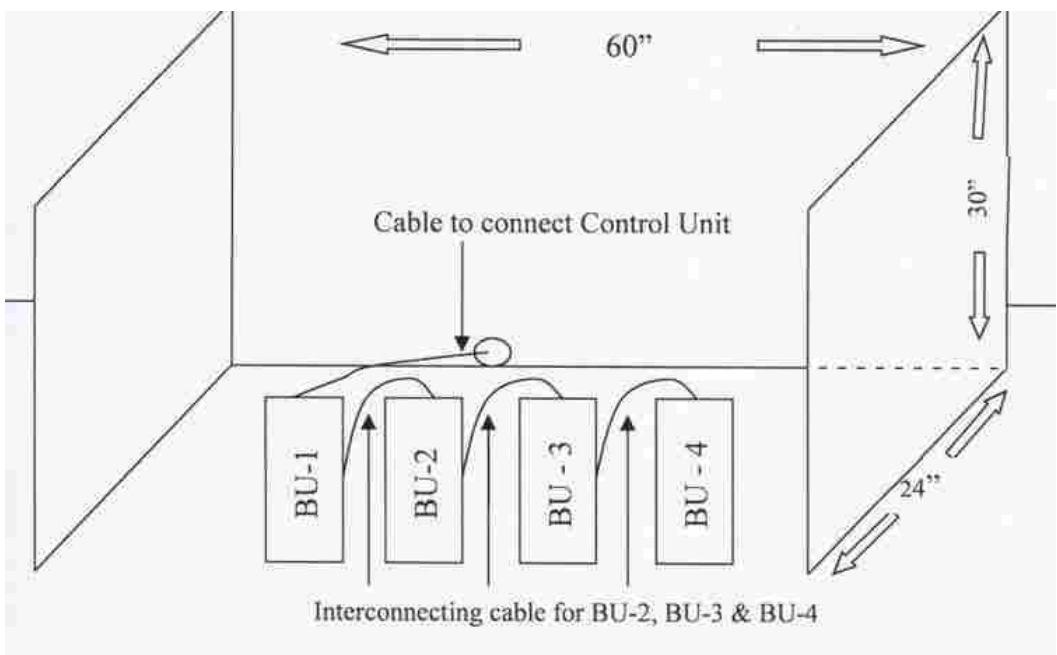

### CASCADING OF FOUR BALLOTING UNITS

**(Register for Preparation of EVMs)**

**Name of State/UT:**

**Name of District:**

**Name of Assembly/Parliamentary Constituency:**

**Address of Preparation of EVM hall:**

**Date:**

S.No.	Name of candidate	Name of representative of candidates with party affiliation, if any	Identity document No. with date	Signature of candidates/His representative	Remarks, if any.

Note: If a candidate or his representative is absent the proof of due service of notice to the candidate should be pasted in the register.

(Name and signature of engineers of BEL/ECIL with ID No.)

(Name, designation, signature of officers nominated by District Election Officer)

**Annexure - 11**

**(Certification of EVMs by BEL/ECIL)**

**Name of State/UT:**

**Name of District:**

**Name of Assembly/Parliamentary Constituency:**

**Address of hall:**

**Date:**

It is certified that tests prescribed by BEL/ECIL to ascertain that all components are original were carried out on the Balloting Unit listed below on..... (date). On the basis of these tests it is certified that all components of the Balloting Unit listed below are original.

**BU Identification No.**

**(Name & signature of BEL/ECIL engineers with ID No.)**

(Certification of EVMs by BEL/ECIL)

(Mock Poll certification during Preparation of EVMs)

Date:.....

Name of State/UT:

Name of District:

Name of Assembly/Parliamentary Constituency:

Address of hall:

It is certified that I have done mock poll on..... EVMs and I am fully satisfied with the functioning of EVMs.

S.No.	Name of candidate	Name of representative of candidates with party affiliation, if any	Identity document No. with date	Signature of candidate/his representative	Remarks, if any.



**Annexure - 13**

**(Mock Poll certification during Preparation of EVMs)**

**Date:.....**

**Name of State/UT:**

**Name of District:**

**Name of Assembly/Parliamentary Constituency:**

**Address of hall:**

It is certified that a printout of the result of mock poll as well as a sequential print out of every vote polled during the mock poll has been taken out from ..... EVMs picked up by me. There are no discrepancies between the votes polled during the mock poll and result in the print out.

S.No.	Name of candidate	Name of representative of candidate with party affiliation, if any	Identity document No. with date	Signature of candidate/his representative	Remark, if any.

**(Register for Sealing of Balloting Unit of EVMs using Pink Paper Seal)**

**Name of State/UT:**

**Name of District:**

**Address of FLC hall:**

**Date:**

It is certified that the sealing of the Balloting Units using Pink Paper Seals has been done in my presence. I have put my signature on the Pink Paper Seals after sealing of the Balloting Units and I am satisfied with the sealing of the Balloting Units.

Sl. No.	Unique ID No. of Balloting Unit	Pink Paper Seal Number

S.No.	Name of candidate	Name of political party with party affiliation, if any	Identity document No. with date	Signature of candidate/ his representative

**Annexure - 15**

**Mock Poll Certificate**

This is certified that I, ..... Presiding Officer at the Polling Station No.....of ..... Assembly Constituency (or the ..... Assembly segment under ..... Parliamentary Constituency) conducted the mock poll at ..... AM today, the poll day i.e. .... (date), following scrupulously all the instructions issued by the Election Commission of India, using –CU of Serial No. (as printed on back-side of the CU)..... BU of Serial No. (as printed on back-side of the BU)..... VVPAT Unit of Serial Number (if used) .....

1. A total of ..... votes were cast for each candidate and also for NOTA.
2. It was verified that the LED light was getting lit up against the correct candidate /NOTA button, when the button was pressed and beep sound was properly heard.
3. The candidate-wise detail of votes polled during mock-poll and result displayed, is as under:

S. No.	Name of the Candidate	Number of votes cast during mock poll	Number of votes displayed in CU on checking the result	Number of Printed Paper Slips, as per counting on checking mock poll result (if VVPAT used)	Votes Cast and Result displayed & Printed Paper Slip count (if VVPAT used) Talled with each other (YES/NO)
	NOTA				
	Total				

4. I have cleared the memory of the EVM and also removed the printed paper slips of VVPAT after the mock poll and verified that the memory has been cleared, by pressing the Total button and seeing the Total is shown as '0'.
5. At the time of mock poll the following polling agents representing the candidates whose names mentioned against the names of such agents were present and I have obtained their signatures.
6. Poll Start Date and Time seen on the display of CU at the time of start of actual poll ..... (To be filled in case of Post-2006 EVMs).

S.No.	Name of Polling Agent	Name of Party	Name of candidate	Sign of Polling Agent
1.				
2.				
3.				
4.				
5.				

or

At the time scheduled for mock poll no polling agent was present/the agent of only one contesting candidate was present. After waiting for fifteen more minutes, I conducted the mock poll along with other polling staff at .....AM.

Signature of Micro-Observer (if posted at the polling station)

Date:

Time:

Name & Signature of the Presiding Officer  
 Polling Station No .....  
 Polling Station Name.....

**(Report on getting result data from Control Unit whose CLOSE button was not pressed by Presiding Officer at the end of poll)**

**Name of State/UT:**

**Name of District:**

**Name of election:**

**Number & Name of Assembly/Parliamentary Constituency:**

**Date of Counting:**

It is certified that the result has been obtained from the following Control Unit(s) after pressing CLOSE button in the presence of the contesting candidates/their counting agents. The result of the election has been declared taking into consideration the result from this machine as well.

Sl. No.	Polling Station No.	Unique ID No. of Control Unit	Detailed Report	No. of votes polled in the Control Unit as per Form 17C

**Final statement showing votes polled by the winning and runner up candidates**

S.No.	Name of candidate	Party affiliation, if any	Votes polled

**(Name & Signature of Returning Officer)**

**(Name & Signature of Observer)**

**Annexure - 17**

**(Report on discrepancy in total votes shown in the Control Unit whose CLOSE button was not pressed by Presiding Officer at the end of poll and as mentioned in Form 17-C)**

**Name of State/UT:**

**Name of District:**

**Name of election:**

**Number & Name of Assembly/Parliamentary Constituency:**

**Date of Counting:**

It is certified that the discrepancy has been noticed in the total votes polled in the following Control Unit(s), after pressing TOTAL button of the Control Unit and comparing it with the total votes polled mentioned in Form 17-C.

S.No.	Polling Station No.	Unique ID No. of Control Unit	No. of votes polled displayed by Control Unit on pressing TOTAL button	No. of votes polled in the Control Unit as per Form 17C	Remarks

**Final statement showing votes polled by the winning and runner up candidates**

S.No.	Name of candidate	Party affiliation, if any	Votes polled

As the margin of votes between the candidate having highest votes and the runner up is more than the votes polled mentioned in the Form 17C relating to the Control Unit(s) mentioned above, the matter is being referred to the Commission for permission to set aside the votes polled in the said Control Units (s) and to declare the result.

**(Name & Signature of Returning Officer)**

**(Name & Signature of Observer)**

**Annexure - 18**

**(Report on discrepancy in total votes shown in the Control Unit whose CLOSE button was not pressed by Presiding Officer at the end of poll and as mentioned in Form 17-C)**

**Name of State/UT:**

**Name of District:**

**Name of election:**

**Number & Name of Assembly/Parliamentary Constituency:**

**Date of Counting:**

It is certified that the discrepancy has been noticed in the total votes polled in the following Control Unit(s), after pressing TOTAL button of the Control Unit and comparing it with the total votes polled mentioned in Form 17-C.

S.No.	Polling Station No.	Unique ID No. of Control Unit	No. of votes polled displayed by Control Unit on pressing TOTAL button	No. of votes polled in the Control Unit as per Form 17C	Remarks

As the margin of votes between the candidate having highest votes and the runner up is less than the votes polled mentioned in the Form 17C relating to the Control Unit(s) mentioned above, the matter is being referred to the Commission for appropriate orders.

Statement showing votes polled by the candidates having highest votes and runner up

S.No.	Name of candidate	Party affiliation, if any	Votes polled

**(Name & Signature of Returning Officer)**

**(Name & Signature of Observer)**

**Annexure - 19**

**(Report on retrieving result data from Control Unit by using Auxiliary Display Unit and Printer)**

**Name of State/UT:**

**Name of District:**

**Name of election:**

**Number & Name of Assembly/Parliamentary Constituency:**

**Date of Counting:**

It is certified that the result has been retrieved from the following malfunctioned Control Unit(s) by using Auxiliary Display Unit/Printer in the presence of the contesting candidates/their counting agents. The result of the election has been declared taking into consideration the result from this machine as well.

Sl.No.	Unique ID No. of Control Unit	Detailed Report	No. of votes polled in the malfunctioned Control Unit as per Form 17C

**Final statement showing votes polled by the winning and runner up candidates**

S.No.	Name of candidate	Party affiliation, if any	Votes polled

**(Name & Signature of Returning Officer)**

**(Name & Signature of Observer)**

**Annexure - 20**

**(Report on non-retrieving result from Control Unit by using Auxiliary Display Unit and Printer)Name of State/UT:**

**Name of State/UT:**

**Name of District:**

**Name of election:**

**Number & Name of Assembly/Parliamentary Constituency:**

**Date of Counting:**

It is certified that the result could not be retrieved from the following malfunctioned Control Unit (s) by using Auxiliary Display Unit and Printer.

Sl.No.	Unique ID No. of Control Unit	Detailed Report	No. of votes polled in the malfunctioned Control Unit as per Form 17C

**Final statement showing votes polled by the winning and runner up candidates**

S.No.	Name of candidate	Party affiliation, if any	Votes polled

**(Name & Signature of Returning Officer)**

**(Name & Signature of Observer)**



**Annexure - 21**

**(Report on non-retrieving result from Control Unit by using Auxiliary Display Unit and Printer)**

**Name of State/UT:**

**Name of District:**

**Name of election:**

**Number & Name of Assembly/Parliamentary Constituency:**

**Date of Counting:**

It is certified that the result could not be retrieved from the following malfunctioned Control Unit (s) by using Auxiliary Display Unit and Printer.

Sl.No.	Unique ID No. of Control Unit	Detailed Report	No. of votes polled in the malfunctioned Control Unit as per Form 17C

**Final statement showing votes polled by the winning and runner up candidates**

S.No.	Name of candidate	Party affiliation, if any	Votes polled

**(Name & Signature of Returning Officer)**

**(Name & Signature of Observer)**

**FORM 17 C**

[See rules 49S and 56C(2)]

**PART I – ACCOUNT OF VOTES RECORDED**

Election to House of the People/Legislative Assembly of the State/Union Territory .....  
from..... constituency.

Number and Name of Polling Station: .....

Identification Number of voting Control Unit.....

Machine used at the Polling Station: Balloting Unit.....

Printer (if used).....

1. Total number of electors assigned to the Polling Station
2. Total number of voters as entered in the Register for Voters (Form 17A)
3. Number of voters deciding not to record votes under rule 49-O
4. Number of voters not allowed to vote under rule 49M
5. Test votes recorded under rule 49MA (d) required to be deducted-
 

(a)	total number of test votes to be deducted:	Total No. Sl.No.(s) of elector(s) in Form 17A
(b)	Candidate(s) for whom test vote(s) cast:	Sl.No. Name of candidate No. of votes
	.....	.....
	.....	.....
6. Total number of votes recorded as per voting machine:.....
7. Whether the total number of votes as shown against item 6 tallies with the total number of votes as shown against item 2 minus numbers of voters deciding not to record votes as against item 3 minus number of voters as against item 4(i.e. 2-3-4) or any discrepancy noticed:.....
8. Number of voters to whom tendered Ballot papers were issued under rule 49P:.....
9. Number of tendered Ballot papers:
 

	Total	From	To
(a)	received for use	.....	.....
(b)	issued to electors	.....	.....
(c)	not used and returned	.....	.....
10. Account of papers seals

**Signature of polling agents**

1. Paper seals supplied for use: Total No..... 1.....  
Sl.No. from..... To .....
  2. Paper seals used: Total No..... 2.....  
Sl.No. from..... To .....
  3. Unused paper seals returned to  
Returning Officer: Total No..... 3.....  
Sl.No. from..... To .....
  4. Damaged paper seal, if any: Total No..... 4.....  
Sl.No. from..... To .....
- 5.....  
6.....

Date.....

Place.....

**Signature of Presiding Officer**  
**Polling Station No.....**

**PART II- RESULT OF COUNTING**

Sl.No. of candidate	Name of candidate	Number of votes as displayed on control unit	Number of test votes to be deducted as per item 5 of Part I	Number of valid votes.
(1)	(2)	(3)	(4)	(5)

- 1.
- 2.
- 3.
- 4.
- 5.
- 6.

---

Total

---

Whether the total number of votes shown above tallies with the total number of votes shown against item 6 of Part I or any discrepancy noticed between the two totals.

---

Place.....

Date.....

Signature of Counting Supervisor

Name of candidate/election agent/counting agent

Full signature

- 1.
  - 2.
  - 3.
  - 4.
  - 5.
  - 6.
  - 7.
- 

Place.....

Date.....

Signature of Returning Officer

**PLEASE COME AND VOTE**

**“ELECTION COMMISSION OF INDIA HAS INTRODUCED VOTER VERIFI-  
ABLE PAPER AUDIT TRAIL TO ENABLE YOU AS A VOTER TO PHYSICALLY  
VERIFY THE VOTE CAST BY YOU”**

**PLEASE PAY ATTENTION TO THE FOLLOWING WHEN YOU GO TO CAST  
VOTE**

**WHEN YOU PRESS CANDIDATE’S BUTTON ON BALLOTING UNIT PLEASE  
WATCH:**

- (i) THE LIGHT GLOWING ON THE BALLOTING UNIT AGAINST THE  
NAME OF YOUR CANDIDATE;**
- (ii) ALSO AT THE SAME TIME WATCH THE PAPER SLIP PRINTED BY  
PRINTER (KEPT ALONGSIDE BALLOTING UNIT) IN THE WINDOW  
OF THE PRINTER SHOWING SERIAL NUMBER, NAME AND SYMBOL  
OF THE CANDIDATE OF YOUR CHOICE; AND**
- (iii) LISTEN ALSO TO THE BEEP SOUND WHEN YOU CAST YOUR VOTE.**

**TROUBLE SHOOTING**  
**HANDLING OF CU-BU-VVPAT FAILURES/ERRORS DURING POLL**  
**PREPARATION OF POLLING OFFICIALS FOR FAULT HANDLING-**  
**SUGGESTIONS**

Certain contingencies may arise during the polling process which may require certain actions. These are as follows: -

- a. In case the CU or the BU does not work properly, (I) SWITCH OFF the CU, DON'T SWITCH IT ON AGAIN (ii) Replace the complete set of EVM namely BU and CU with VVPAT (i.e. CU, BU and VVPAT) by another set of BU, CU and VVPAT. (iii) Continue the poll with the new EVM set.
- b. In case Display Penal of the Control Unit displays "Link Error" -
  - i) Check that the cable connections are made properly by visual inspection (DON'T REMOVE and RECONNECT THE CONNECTORS);
  - ii) If "Link Error" still persists, replace the complete set of EVM with VVPAT (i.e. CU, BU and VVPAT).
- c. In case the "VVPAT Status Display Unit (VSDU) displays 'Error Code – 1 Replace Battery'".

Switch off the Control Unit and replace the Power Pack of VVPAT printer. *It shall be ensured that in no case replacement of power pack is done without switching off the Control Unit.*

- d. In case the VSDU displays "Error Code – 2 Replace Printer" and the Presiding Officer has not pressed the BU enable button then-

Switch off the Control Unit and replace the defective VVPAT unit with the new VVPAT unit. *It shall be ensured that in no case replacement of VVPAT unit is done without switching off the Control Unit.*

- e. In case the Presiding Officer has pressed BU enable Button and the Voter has pressed the Candidate Button of the Balloting Unit and complains that 'Paper Slip' has not been printed or the Paper Slip printed by the VVPAT unit has not been cut and hanging against the display window then:

- i) In case the busy lamp of the Control Unit is not glowing, and no Message/Error is displayed on VSDU, the complaint should be considered as baseless and rejected.
- ii) In case busy lamp is glowing on the Control Unit, and no Message/Error is displayed on VSDU, the Voter shall be requested to go into the Voting Compartment once again and Press the Candidate Button of Balloting Unit of his choice.
- iii) If even than busy lamp is glowing on the Control Unit, please check the display of the VSDU of VVPAT. If VSDU busy lamp is also glowing and VSDU has no display message, please switch OFF the Control Unit and replace the VVPAT unit.
- iv) The last voter whose paper slip has not been printed by VVPAT or has not been cut should be allowed to cast his vote after the VVPAT unit has been replaced. Please keep in mind that the vote is not recorded in the CU electronically unless the paper slip has been printed, it is cut and falls in the drop box of VVPAT. Therefore if VVPAT has not printed the paper slip, or the printed paper slip has not been cut, the last voter whose paper slip has not been printed by VVPAT or has not been cut should be allowed to cast his vote after the VVPAT unit has been replaced.
- v) In case the printed paper slip has not been cut and is hanging from the paper roll, replace the Printer, but no effort should be made to make it fall into the drop box. It should be allowed to remain hanging, as it is not to be counted at the time of counting of the printed paper slips. The details of such an occurrence should be clearly recorded in the Presiding Officers diary in the following format:
  - i. The date and time of the occurrence.
  - ii. The name of the voter and his serial number in part in the electoral roll who was allowed to cast his vote after replacement of VVPAT.
  - iii. Whether the voter cast his vote after replacement of VVPAT or went away without casting his vote.

- iv. The Total number of votes cast before the occurrence.
- f. In case a voter alleges after recording his vote that the printed paper slip generated by the printer has shown the name or symbol of a candidate other than the one he voted for, action should be taken as per provisions of Rule 49MA of the Conduct of Elections (Amendment) Rules, 2013, as mentioned below:-
- i) Obtain a declaration from the complainant in the Declaration Form supplied to you for this purpose under his/her signature/thumb impression;
  - ii) Proceed to the voting compartment alongwith the voter (complainant) and polling agents present in the polling station at that moment;
  - iii) The voter shall be asked to cast a test vote in favour of any candidate and make second entry related to that elector in the Form-17A;
  - iv) Observe carefully whether the Printer has printed the paper slip correctly;
  - v) If the complaint of the elector is found genuine, the Presiding Officer shall report the facts immediately to the Returning Officer, stop further Poll at the polling station;
  - vi) If the complaint of the elector is found false, make a remark to that effect against the second entry relating to that elector in Form-17A mentioning the serial number and name of the candidate for whom such test vote has been recorded and obtain the signature or thumb impression against such remark. Further make necessary entries regarding such test vote in item 5 in Part-I of Form 17-C.



**Annexure-25**

**CHECK LIST OF ADDITIONAL ITEMS OF POLLING MATERIALS TO BE PROVIDED TO THE POLLING PARTY**

- |    |  |   |           |
|----|--|---|-----------|
| 1. | Voter Verifiable Paper Audit Trail (VVPAT) Printer Unit                              | : | 2 No.     |
| 2. | VVPAT Status Display Unit (VSDU)   | : | 2 No.     |
| 3. | Additional Power Pack for VVPAT Printer Unit   | : | 1 No.     |
| 4. | Carrying Case for the VVPAT system   | : | 2 No.     |
| 5. | Envelope made of thick black paper<br>(For sealing printed paper slips of Mock Poll) | : | 2 Nos.    |
| 6. | Plastic Box for Black Paper Envelope Sealing   | : | 1 No.     |
| 7. | Pink Paper Seal for sealing Plastic Box  | : | 2 Nos.    |
| 8. | Form of declaration by elector under rule 49MA<br>of the Conduct of Elections Rules  | : | 10 copies |
| 9. | Operational Manual of VVPAT  | : | 1 No.     |

General/Bye-Election to.....

Sl. No. and Name of Parliamentary/Assembly Constituency.....

No. and Name of Polling Station.....

**FORM OF DECLARATION BY ELECTOR UNDER RULE 49MA OF CONDUCT OF ELECTIONS RULES, 1961**

1. I hereby solemnly declare and affirm under sub-rule (1) of Rule 49 MA of the Conduct of Elections Rules 1961 that the paper slip generated by the printer attached to the Balloting Unit has shown the name and/or symbol of a candidate other than the candidate for whom I voted by pressing the concerned blue button against the name and symbol of the candidate of my choice on the Balloting Unit. I am ready to cast a test vote again to show that the allegation made by me is true and bonafide.

(2). I am aware of the penal provisions of Section 177 of the IPC that I shall be liable to be punished with imprisonment for a term which may extend to six months, or with fine which may extend to one thousand rupees, or with both, if the declaration given by me in para 1 above to the Presiding Officer appointed under Section 26 of the RP Act, 1951 is found to be incorrect.

Signature/Thumb impression of the Elector  
Name of the Elector.....  
Father/Mother/Husband's Name.....  
Part No. of elector roll.....  
Sl. No. of elector in that Part.....  
Sl. No. in Register of Voters (Form 17A).....

Dated.....

Certified that the above declaration was made and subscribed by the elector above named before me.

Signature of the Presiding Officer  
.....

Dated.....

## SELECTED REFERENCES

- I. Commission’s letters No. 51/8/7/2007-PLN-IV dated 12/10/2007.
- II. No. 464/OBS/EVM/2007 PLN-IV dated 12/10/2007
- III. No. 51/8/7/2008-EMS (Inst.-I) dated 11/08/2008
- IV. No. 51/8/2009-EMS dated 12/02/2009

\*\*\*\*\*

## IMPORTANT JUDGEMENTS

### 1. **Kerala High Court (A C Jose Vs Sivan Pillai and Ors ELR 23)**

Shri A C Jose filed an election petition before the Kerala High Court. The main plea of the petitioner was that the Electronic Voting Machines had been used in Parur Assembly Constituency in Kerala in May 1982 without the authority of law in the 1951 Act and the rules made thereunder.

The Kerala High Court dismissed the election petition on 12.10.1982, upholding the use of the machines by the Election Commission in exercise of its inherent powers under Article 324.

Shri A C Jose filed an appeal before the Hon'ble Supreme Court (A C Jose Vs Sivan Pillai and Ors AIR 1984 SC 921). The Supreme Court struck down the use of these machines in Parur Assembly Constituency in Kerala on 5th March, 1984. The Supreme Court held that the law provided for the conduct of election by using Ballot papers and Ballot boxes and the Election Commission could not use voting machines in the absence of statutory provisions providing for their use.

### 2. **Madras High Court (All India Anna Dravida Munnetra Kazhagam, etc. Vs Chief Election Commissioner of India and Ors Writ Petition Nos. 3346, 3633, 4417, 4945, etc of 2001)**

The issues of unconstitutional use of EVMs and possible tampering of EVM have been raised before the Madras High Court. The Madras High Court did not accept those allegations and contentions and dismissed all the writ petitions on 10.04.2001. The Hon'ble Madras High Court also categorically ruled out any question of tampering of the EVMs and also made the following observations:

*"There is also no question of introducing any virus or bugs for the reason that the EVMs cannot be compared to personal computers. The programming in computers, as suggested, has no bearing with the EVMs. The computer would have inherent limitations having connections through Internet and by their very design, they may allow the alteration of the programme but the EVMs are independent units and the programme in EVM is entirely a different system."*

The petitioners took the matter to the Hon'ble Supreme Court (All India Anna Dravida Munnetra Kazhagam, etc. Vs Chief Election Commissioner of India and

Ors 2002 UJ (1) 387, 202 (TL/S) 36062). The Supreme Court dismissed the special leave petition on 23.04.2001, agreeing with the decision of the high court that the impugned Section 61A was valid.

**3. Delhi High Court (Viplav Sharma Vs Union of India and Ors CWP No. 5521 of 2004; Kunwar GS Chahan Vs Union of India CPW No. 5906 of 2004)**

In these cases, it was contended that the Election Commission could use electronic voting machines under Section 61A only in selected constituencies having regard to the circumstances of each case, and not routinely in all the assembly constituencies in a state. The above petitions were dismissed by the Delhi High Court on 23.5.2005.

**4. Karnataka High Court (Michael Fernandes Vs C K Jafer Sharif and Ors Election Petition No. 29 of 1999)**

The issue of possible tampering of EVM has been raised before the Karnataka High Court. After going into all aspects of the technological soundness and the administrative measures involved in the use of EVMs at elections in India, have held that the EVMs in India are credible, reliable and totally tamperproof. The Hon’ble Karnataka High Court held that ‘This invention is undoubtedly a great achievement in the electronic and computer technology and a national pride’.

**5. Bombay High Court (Nagpur Bench) (Banwarilal Purohit Vs Vilas Muttemwar and Ors Election Petition No. 1 of 2004)**

The issue of possible tampering of EVM has also been raised before the Bombay High Court (Nagpur Bench). The Hon’ble Bombay High Court (Nagpur Bench), examined the experts produced by the petitioner as witness before the High Court. The order of the Hon’ble High Court records that the two experts produced as witnesses admitted that the hardware and software used in the EVMs are matters not known to public at large, or even experts including the witnesses, and they admitted that the information or data in the EVMs is not made open unauthorisedly.

**6. Kerala High Court (TA Ahammed Kabeer Vs AA Azeez and Ors Election Petition No. 4 of 2001)**

In one of the cases as directed by the Hon'ble High Court of Kerala in Election Petition No.4/2001, the process of detecting votes cast by impersonators was carried out before the Hon'ble Court in the case of General Election from 125-Evavipuram Assembly Constituency in Kerala in 2001. The High Court in its order dated 6.2.2002 had recorded its appreciation on the efficiency of the mechanism. The judgment of the Kerala High Court in the said Election Petition was upheld by the Hon'ble Supreme Court in Civil Appeal (AIR 2003 SC 2271).

\*\*\*\*\*

## FREQUENTLY ASKED QUESTIONS ON ELECTRONIC VOTING MACHINES

**Q1** What is an Electronic Voting machine? In what way its functioning is different from the conventional system of voting?

**Ans.** An Electronic Voting Machine consists of two Units – a Control Unit and a Balloting Unit. Balloting unit has a five-meter cable, which is used to join the Control Unit with the Balloting Unit. The Control Unit remains with the Presiding Officer or a Polling Officer and the Balloting Unit is placed inside the voting compartment. The Polling Officer in-charge of the Control Unit presses the ‘Ballot’ Button provided on the Control unit for releasing the Ballot for the voter. It enables the voter to cast his vote by pressing the ‘Candidate’ button (blue button) on the Balloting Unit against the candidate and symbol of his choice.

**Q2** Who has devised the EVMs?

**Ans.** The EVMs have been devised and designed by Election Commission in collaboration with two Public Sector undertakings i.e., Bharat Electronics Ltd., Bangalore (Ministry of Defence) and Electronic Corporation of India Ltd., Hyderabad (Department of Atomic Energy).

**Q3.** How can EVMs be used in areas where there is no electricity?

**Ans.** EVMs do not require electricity. EVMs run on an ordinary 7.5 volt alkaline Power -pack (manufactured using 5 AA size cells of 1.5 volt each) supplied by Bharat Electronics Ltd., Bangalore and Electronic Corporation of India Ltd., Hyderabad. Therefore, even in areas with no electricity connections, EVMs can be used.

**Q4.** What is the maximum number of votes, which can be cast in EVMs?

**Ans.** A maximum of 3840 votes can be cast in old version EVMs (2000-05 model) and 2000 votes in case of new version EVMs (2006 onwards model).

**Q5. What is the maximum number of candidates, which EVMs can cater to?**

**Ans.** EVMs can cater to a maximum of 64 candidates (including NOTA). There is provision for 16 candidates in one Balloting Unit. If the total number of candidates exceeds 16, a second Balloting Unit can be linked in series to the first Balloting Unit. Similarly, if the total number of candidates exceeds 32, a third Balloting Unit can be attached and if the total number of candidates exceeds 48, a fourth Balloting Unit can be attached to cater to a maximum of 64 candidates (Including NOTA).

In EVMs manufactured after 2013(Upgraded Post-2006 version) 24 Balloting units can be attached to one control unit catering to a maximum of 384 candidates (including NOTA).

**Q6. What is the cost of the EVM? Is it not too expensive to use EVMs?**

**Ans.** The cost of one EVM (One Control Unit, one Balloting Unit)

1989-90 model EVM- Rs. 5,500/- per unit

2000-05 model EVM- Rs.8,670/- per unit

2006 onward model EVM- Rs. 8,670/- per unit (Tentative Cost)

.....excluding excise duty, sales tax and transportation etc.

Even though the initial investment is somewhat high, this is subsequently neutralized by the savings in the matter of printing of Ballot papers in lakhs, their transportation, storage etc., and the reduction in the counting staff and the remuneration paid to them.

**Q7. In our country a sizeable section of the population being illiterate. Will it not cause problems for the illiterate voters?**

**Ans.** In fact, voting by EVMs is simpler compared to the conventional system, where one has to put the voting mark on or near the symbol of the candidate of his choice, fold it first vertically and then horizontally and thereafter put it into the Ballot box. In EVMs, the voter has to simply press the blue button against the name of the candidate and symbol of his choice and the vote is recorded. Rural and illiterate people had no difficulty in recording their votes and, in fact they have welcomed the use of EVMs.



**Q8 With Ballot boxes counting is done after mixing the Ballot papers. Is it possible to adopt this system when EVMs are used?**

**Ans.** Yes, it is possible by using a device named ‘Totalizer’. Totalizer can accommodate upto 14 control units at a time to count votes, without revealing the candidate-wise count of individual control unit. But, presently this is not used because for using ‘Totalizer’ amendment in law is required. The same is pending with the Ministry of Law & Justice, Govt. of India.

**Q9 How long the Control Unit stores the result in its memory?**

**Ans.** The Control Unit can store the result in its memory for 10 years and even more.

**Q10 Is it possible to vote more than once by pressing the button again and again?**

**Ans.** No. As soon as a particular button on the Balloting Unit is pressed, the vote is recorded for that particular candidate and the machine gets locked. Even if one presses that button further or any other button, no further vote can be recorded, unless ‘Ballot’ button provided on the Control Unit is pressed to release the Ballot. This way the EVMs ensure the principle of “one man, one vote”.

**Q11 How can a voter be sure that the EVM is working properly and his vote has been recorded correctly?**

**Ans.** As soon as the voter presses the ‘Candidate’ button (blue button) on the Balloting unit against the name of the candidate and symbol of his choice, a tiny red lamp glows against the name and symbol of the candidate for whom vote is cast and simultaneously a long beep sound is heard. Thus, there are both audio and visual indications for the voter to be assured that EVM is working properly and his vote has been recorded correctly.

**Q12 In the conventional system, it will be possible to know the total number of votes polled at any particular point of time. In EVMs ‘Result’ portion is sealed and will be opened only at the time of counting. How can the total number of votes polled be known on the date of poll?**

**Ans.** In addition to the 'Result' button, there is a 'Total' button on EVMs. By pressing this button the total number of votes polled upto the time of pressing the button will be displayed without indicating the candidate-wise tally.

**Q13** **The Balloting Unit has provision for 16 candidates. In a constituency, there are only 10 candidates. If the voter presses any of the buttons from 11 to 16, will it not lead to wastage of votes?**

**Ans.** No. If there are only 10 candidates in a constituency, the 'Candidate' buttons provided at Sl. No. 11 to 16 shall be masked at the time of preparation of EVM by Returning Officer. Therefore, there is no question of any voter pressing any of the buttons for candidates 11 to 16.

**Q14** **Ballot boxes are engraved so as to avoid any scope for complaint of replacement of these boxes. Is there any system of numbering EVMs?**

**Ans.** Yes. Each Control Unit and Balloting Unit has a unique ID Number, which is engraved on each unit. The list containing ID number of EVM (Balloting Unit & Control Unit) to be used in a particular polling station is prepared and provided to the contesting candidates/their agents.

**Q15** **In the conventional system, before the commencement of poll, the Presiding Officer shows to the polling agents present there that the Ballot box to be used in the polling station is empty. Is there any such provision to satisfy the polling agents that there are no votes already recorded in the EVMs?**

**Ans.** Yes. Before the commencement of poll, the Presiding Officer demonstrates to the polling agents that there is no vote already recorded in the machine by pressing the total button. Thereafter, he conducts a mock poll by asking the polling agents to record their votes and takes the result to satisfy them that the result shown is strictly according to the choice recorded by them. Thereafter, the Presiding Officer presses the clear button. It clears the result of the mock poll before commencing the actual poll. He then again shows to polling agents, by pressing 'Total' button that it shows '0'. Then he seals the Control Unit.

**Q16** How can one rule out the possibility of recording further votes at any time after close of the poll and before the commencement of counting by unscrupulous elements?

**Ans.** After completion of poll i.e. when the last voter has voted, the Officer in-charge of the Control Unit presses the ‘Close’ Button. Thereafter, the EVM does not accept any vote. After the close of poll, the Control Unit is switched off and thereafter the Balloting Unit is disconnected from the Control Unit and kept separately in the respective carrying cases and sealed. Further, the Presiding officer has to hand over to each polling agent a copy of the account of votes recorded. At the time of counting of votes, the total votes recorded in a particular control unit is tallied with this account and if there is any discrepancy, this can be pointed out by the Counting Agents.

**Q17** When was the EVM first used in elections?

**Ans.** EVMs were first used in 50 polling stations of Parur Assembly Constituency during General Election of the Kerala Legislative Assembly held in May, 1982.

**Q18** Whether EVMs are being used regularly in elections since 1982?

**Ans.** No. After 1983, the machine could not be used till November, 1989, as the Hon’ble Supreme Court ruled in an Election Appeal (A.C. Jose Vs. Sivan Pillai & other- AIR 1984 SC921), challenging the use of the EVMs in Parur Assembly Constituency during General Election of the Kerala Legislative Assembly held in May, 1982, that for electronic recording of votes, there should be specific provision in the law to give legal sanctions for the use of EVMs.

**Q19.** Whether use of EVMs in an election is legal or not?

**Ans.** Use of EVMs in an election is legal. In December, 1988, a new Section 61A was inserted in the Representation of the People Act, 1951 empowering the Election Commission to use electronic voting machines.

**Q20** Whether matter regarding use of EVMs was examined by any Committee or not? If yes, the decision of the said Committee.

**Ans.** The matter regarding use of EVMs was referred by the Government of India to Electoral Reforms Committee, appointed by the Central Government in February, 1990 consisting of several recognized National and State Parties. The EVMs were demonstrated before that Committee and, though the Committee was satisfied about their functioning, it appointed a Technical Experts Committee, consisting of Prof. S. Sampath, the Chairman, RAC, Defence Research and Development Organization, Prof. P.V. Indiresan, IIT Delhi and Dr. C. Rao Kasarbada, the Director Electronics Research and Development Centre, Trivandrum, for technical evaluation of the machines. The aforesaid Technical Experts Committee examined the EVMs and they recommended for the EVMs.

**Q21.** What will happen if the EVM in a particular polling station goes out of order?

**Ans.** On poll day Zonal/Area/Sector Magistrates keep on patrolling with reserved EVMs. In case, EVM of a particular polling station goes out of order then the same is replaced with a new one. The votes recorded until the stage when the EVM went out of order remains safe in the memory of the Control Unit and it is sufficient to proceed with the polling after replacing the EVM with new EVM and there is no need to start the poll from the beginning. On counting day, both EVMs are counted to give the result of that polling station.

**Q22** Can booth – capturing/mass rigging be prevented by the use of EVMs?

**Ans.** Booth capturing/mass rigging by miscreants to intimidating the polling personnel and stamping the Ballot papers on the symbol and escaping in a matter of minutes, this can be prevented by the use of EVMs. The EVMs are programmed in such a way that the EVM can record only five votes in a minute. As recording of votes has necessarily to be through Control Unit and Balloting Unit, whatever be the number of miscreants they can record vote only at the rate of 5 per minute. In the case of Ballot papers, the miscreants can distribute all the 1000 odd Ballot papers assigned to a polling station, among themselves, stamp them, stuff them into the Ballot Boxes

and run away before the police reinforcements reach. In half-an-hour, the miscreants can record only a maximum of 150 votes by which time; chances are the police reinforcement would have arrived. Further, the Presiding Officer or one of the Polling Officers can always press the “close” button as soon as they see some intruders inside the polling station. It will not be possible to record any vote when once the ‘close’ button is pressed and this will frustrate the efforts of the booth-capturers.

**Q23 What are the advantages of using EVMs?**

**Ans.** The most important advantage is that the printing of millions of Ballot papers can be dispensed with, as only one Ballot paper is required for fixing on the Balloting Unit at each polling station instead of one Ballot paper for each individual elector. This results in huge savings by way of cost of paper, printing, transportation, storage and distribution. Secondly, counting is very quick and the result can be declared within 2 to 3 hours as compared to 30-40 hours, on an average, under the conventional system. Thirdly, there are no invalid votes under the system of voting with EVMs. Previous General Elections result show that the number of invalid votes was more than the winning margin between the winning candidate and the second candidate, in a number of constituencies. To this extent, the choice of the electorate is more correctly reflected when EVMs are used.

**Q24 Is it possible to program the EVMs in such a way that initially, say upto 100 votes, votes will be recorded exactly in the same way as the ‘blue buttons’ are pressed, but thereafter, votes will be recorded only in favor of one particular candidate irrespective of whether the ‘blue button’ against that candidate or any other candidate is pressed?**

**Ans.** The programme is burnt in the one time programmable/masked chip, which cannot be read. Further, rewriting of program also cannot be done by anyone. Thus, there is absolutely no chance of re-programming the EVMs in a particular way to select any particular candidate or political party.

**Q25 Whether the EVMs can reveal the data that who voted for whom?**

**Ans.** The ECI-EVMs have the facility to reveal that who voted for whom by using a device called 'decoder' which when attached to the EVM can print out statement of voting data showing the order in which the voters voted and to whom (i.e. the serial number pertaining to the particular candidate in the Ballot paper) they voted. But these decoders are never allowed to be put to use as revealing of any such information will violate the secrecy of voting provided under the law. Only on the orders of competent courts, such information can be printed and shown.

**Q26 Whether polled data stored in the EVMs can be manipulated?**

**Ans.** No, The EVM is both mechanically and electronically protected to prevent any tampering/manipulation. The programme (software) used in these EVM is burnt into a One Time Programmable/Masked chip (Hardware) so that it cannot be altered or tampered with. Further these EVMs are not linked either by wire or by wireless system to any other machine or system. Therefore, there is no possibility of manipulation of data.

**Q27 Whether EVMs are checked before using in an election or not?**

**Ans.** Yes. Before elections, First Level Checking (FLC) is done for each EVM by the engineers of manufacturing firms of EVM i.e. M/s Bharat Electronics Limited, Bangalore and M/s Electronics Corporation of India Limited, Hyderabad, to find out any defects. All defective EVMs are kept separately and not used in the election. The FLC is done in presence of representatives of all recognized political parties and is videographed. There are very elaborate guidelines for 'Protocol of the FLC'. After FLC, Pink Paper Seal is affixed appropriately on the Control Unit, so as to ensure that Control Unit can't be opened without damaging this seal. If later at any stage, this seal is found damaged than that EVM is not used for taking poll.

**Q28 Is there any system of allocation of EVM to an Assembly Constituency?**

**Ans.** After First Level Checking of EVMs, the District Election Officers fix up a schedule for randomization of CUs/BUs for distribution of EVMs to Assembly Constituencies in the presence of the representatives of recognized political parties. The randomization

is done by using a Computer in such a way that the CUs/BUs are randomly selected by grouping them to match the poll day requirement including reserve required for each constituency. After first randomization of EVMs, EVMs are stored safely in a Strong Room under very strict security arrangements.

**Q29 Who prepares the EVMs for use in poll and when?**

**Ans.** After finalization of the names of contesting candidates, the Ballot papers for EVMs are printed. Thereafter, the Returning Officers prepare the EVMs. On the day fixed for preparing the CUs/BUs for use in the election, the Returning Officers ensure that the preparation of CUs/BUs is done invariably in the presence of the candidates or their agents or their authorized representatives and also in the presence of the Commission's Observer.

Multilevel thread sealing of various compartments/sections of EVMs is done by Returning Officer during preparation of EVMs in the presence of the candidates/their authorized agents:

1. Thread seal for the “Candidate Set” and Power Pack (Battery) Section of Control Unit after setting of number of contesting candidates and installation of battery.
2. Thread seal for Ballot paper screen of Balloting Unit after fixing of Ballot paper.
3. Thereafter, two thread seals for Ballot paper cover of Balloting Unit.

Thereafter, the Returning Officers do the second randomization of the CUs/BUs to allot the CU/BU to specific polling stations. After that they write the polling station number to which the BU/CU has been randomly allotted in the slot provided for it in the sticker as well as in Address Tags.

**Q30 Where are EVMs stored after preparation of EVMs by Returning Officer?**

**Ans.** The EVMs prepared in aforesaid manner are stored in a strong room in the presence

of the candidates/their agents and the Commission's Observer. The candidates/their agents are allowed to put their seals on the locks of the strong room. A log book is maintained and foolproof security arrangements are made.

**Q31 When is the strong room opened to despatch the EVMs to their respective polling stations?**

**Ans.** After storing of EVMs in the strong room, it is opened, again in the presence of candidates/their agents and Observer, on the day when the polling parties are dispatched to their respective polling stations.

**Q32 Is there any provision to verify the functioning of EVM at polling station?**

**Ans.** Before actual poll, to ensure that EVM is working properly and to clear doubts of the candidates/their authorized agents mock poll is conducted by the Presiding Officer in the presence of the candidates/their authorized agents and mock poll certificate is issued. This is done one hour before scheduled time for commencement of poll.

**Q33 Is there any provision of sealing the EVM at polling station?**

**Ans.** After mock poll, the Presiding Officer seals the Result Section/Bottom Compartment of Control Unit using:-

1. Green paper seal for result section
2. Thread seal for inner door of result section
3. Thread seal for Bottom compartment
4. Thread seal for connector box for cascading Balloting Unit, if any (when there are more than 16 candidates).

**Q34 Where are EVMs stored after poll and before counting?**

**Ans.** After the conduct and close of poll, the polled EVMs are transported under security to the strong room located in the premises of Counting Centre. The candidates/their agents are allowed to follow the vehicles carrying polled EVMs. After all EVMs are



stored in the storage hall, it is sealed in the presence of the candidates/their agents and the Commission’s Observer. The candidates/their agents are permitted to affix their own seals on the locks of the storage hall. In the intervening period, the candidates/their agents are allowed to keep a round-the-clock watch on the storage hall.

**Q35** When is strong room opened after storing polled EVMs?

**Ans.** The strong room is opened; again in the presence of the candidates/their agents and the Commission’s Observer on the day of counting of votes.

**Q36** Where are EVMs stored after counting of votes?

**Ans.** After counting of votes, the EVMs are stored in the strong room; again in the presence of the candidates/their agents and the Commission’s Observer.

\*\*\*\*\*

## Frequent Asked Questions (FAQs) on Voter Verifiable Paper Audit Trail (VVPAT)

**Q1. What is Voter Verifiable Paper Audit Trail (VVPAT)?**

**Ans.** Voter Verifiable Paper Audit Trail is an independent system [consists of two parts, namely, VVPAT Printer and VVPAT Status Display Unit (VSDU)] attached with the Electronic Voting Machines that allows the voters to verify that their votes are cast as intended. When a vote is cast, a slip is printed containing the serial number, name and symbol of the candidate and remains exposed through a transparent window for 7 seconds. Thereafter, this printed slip automatically gets cut and falls in sealed drop box of the VVPAT.

**Q2. Whether VVPAT runs on electricity?**

**Ans:** No. VVPAT runs on a power pack (Battery) of 15 volts.

**Q3. When did Government of India notify the amended Conduct of Elections Rules, 1961 to enable the Election Commission of India to use VVPAT with EVMs?**

**Ans.** The Government of India notified the amended Conduct of Elections Rules, 1961 on 14th August, 2013, enabling the Commission to use VVPAT with EVMs.

**Q4. Where VVPATs were used for first time in India?**

**Ans.** VVPATs with EVMs were used for first time in a bye-election from 51-Noksen (ST) assembly constituency of Nagaland.

**Q5. Who conduct the First Level Checking of VVPATs?**

**Ans:** Only authorised engineers of the manufacturers, namely, Bharat Electronics Limited (BEL) and Electronics Corporation of India Limited (ECIL) conduct the First Level Checking (FLC) of VVPATs in the presence of representative of Political Parties under videography.

**Q6. Where VVPAT Printer and VSDU are kept in a polling station?**

**Ans.** VVPAT consists of a Printer and a VVPAT Status Display Unit (VSDU). Control Unit and VSDU are kept with the Presiding Officer/Polling Officer and Balloting Unit and VVPAT Printer are kept in the voting compartment.

**Q7. What procedure shall be followed in case of complaint about the paper slip generated by the printer has shown the name or symbol of a candidate other than the one he voted for?**

**Ans.** Where printer for paper trail is used, if an elector after having recorded his vote under rule 49M alleges that the paper slip generated by the printer has shown the name or symbol of a candidate other than the one he voted for, the presiding officer shall obtain a written declaration from the elector as to the allegation, after warning the elector about the consequence of making a false declaration.

If the elector gives the written declaration referred to in sub-rule (1), the presiding officer shall make a second entry related to that elector in Form 17A, and permit the elector to record a test vote in the voting machine in his presence and in the presence of the candidates or polling agents who may be present in the polling station, and observe the paper slip generated by the printer.

If the allegation is found true, the presiding officer shall report the facts immediately to the returning officer, stop further recording of votes in that voting machine and act as per the direction that may be given by the Returning Officer.

If, however, the allegation is found to be false and the paper slip so generated under sub-rule (1) matches with the test vote recorded by the elector under sub-rule (2), then, the presiding officer shall-

- (i) make a remark to that effect against the second entry relating to that elector in Form 17A mentioning the serial number and name of the candidate for whom such test votes has been recorded;
- (ii) obtain the signature or thumb impression of that elector against such remarks; and

- (iii) make necessary entries regarding such test vote in item 5 in Part I of Form 17C.”.

**Q8. Who load the Serial numbers, names of candidates and symbols allotted to contesting candidates in VVPAT unit?**

**Ans.** Serial numbers, names of candidates and symbols allotted to them are loaded in VVPAT unit with the help of engineers of manufacturer i.e. ECIL/BEL.

**Q9. Whether test printout of the Serial numbers, names of candidates and symbols loaded in VVPAT is required?**

**Ans.** Yes. A test printout of the Serial numbers, names of candidates and symbols loaded in VVPAT is required to check with the ballot paper placed on Ballot Unit. Thereafter one vote to each candidate will be given to check that the VVPAT is printing the paper slips correctly in respect of all the candidates.

**Q10. Whether additional Polling Official is required in each polling station to handle the VVPAT unit?**

**Ans.** Yes. Additional polling official is required in each polling station to handle the VVPAT unit. The duty of this polling official will be to watch the VVPAT Status Display Unit (VSDU), kept on the presiding officer’s table, continuously during the entire poll process.

**Q11. What action should be taken in case of display of low battery on VSDU?**

**Ans.** In case of low battery message on VSDU, the battery of VVPAT should be immediately replaced with new power pack (battery).

**Q12. What action should be taken in case of display of printer error on VSDU?**

**Ans.** In case of display of printer error on VSDU, VVPAT should be immediately replaced with new VVPAT.

**Q13. Whether changing of paper roll is allowed at polling stations?**

**Ans.** Changing of paper roll is strictly prohibited at polling stations.

**Q14. What is the most important action required to be taken immediately after mock poll at the polling stations?**

**Ans.** The Presiding Officer shall ensure that the data of mock poll is cleared in the Control Unit, without fail, and also remove all the printed paper (ballot) slips from the drop box in the VVPAT unit. The printed paper slips of the mock poll, should be stamped on their back side with rubber stamp having inscription “MOCK POLL SLIP” before keeping and sealing these printed paper slips in the thick black envelope supplied for the purpose. The envelope will be sealed with the seal of the presiding officer.

**Q15. Whether it is advisable to connect or disconnect the connection of VVPAT with EVM at SWITCH ON condition of the Control Unit?**

**Ans.** No. Always ensure that connection and disconnection of VVPAT should be done when Control Unit is in SWITCH OFF condition.

**Q16. Whether Mock poll is required to be done if EVM/VVPAT is replaced during poll process, where VVPAT is being used?**

**Ans.** No.

**Q17. Whether test vote recorded in the Control Unit of EVM is required to be counted at the time of counting of votes?**

**Ans.** No. At the time of counting of votes the test vote recorded for a candidate, as per item 5 in Part I of Form 17C shall be subtracted from the number of votes recorded for such candidate as displayed on the Control Unit.

**Q18. Whether counting of printing paper slips of VVPAT is compulsory on the counting day?**

**Ans.** No. However, if any candidate, or in his absence, his election agent or any of his counting agents make a written request to count the printed paper slips of the VVPAT in respect of any polling station or polling stations, the Returning Officer taking into consideration various factors decides and issue written orders, whether to count or not to count the printed paper slips of the VVPAT.

**Q19. After announcement of the result, whether the printed paper slips of VVPAT (counted or not), the printed paper slips are required to be taken out of the drop box of the VVPAT Printer unit?**

**Ans.** Yes, after announcement of the result, whether printed paper slips of VVPATs are counted or not, the printed-paper slips are to be taken out of the drop box of the printer and kept in a paper envelope made of thick black paper and sealed with red wax with the bilingual secret seal of the Commission provided to the RO for sealing of the documents.

**Q20. Whether Thermal Paper Roll and Battery (Power Pack) are to be taken out from the VVPAT, before keeping the VVPAT units in the separate Strong Room, after declaration of result?**

**Ans.** Yes.

**Q21. Why are the EVMs and VVPATs kept in separate strong rooms after counting?**

**Ans.** As the VVPAT does not have any memory and the printed paper slips are taken out from the drop-box of printer after declaration of result/counting of votes, the unit is free to use in next election. Therefore, the same is kept in separate strong room, so that VVPATs are not blocked in the strong room, if any EP is filed.





“No voter to be left behind”

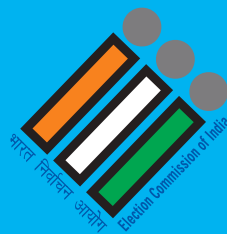

**भारत निर्वाचन आयोग**  
**Election Commission of India**  
Nirvachan Sadan, Ashoka Road, New Delhi-110001